



2006 OFFSHORE RACING RULE (ORR)

A Rating System for Offshore Cruising/Racing Yachts

Published by the

Offshore Racing Association

www.offshorerace.org

ORR OWNER'S QUICK START GUIDE

Brief

The Offshore Racing Rule (ORR) is administered by the Offshore Racing Association (ORA). ORA and US SAILING, the national authority for sailing in the United States, are both responsible for its implementation.

The ORR predicts relative time allowances between boats to permit boats of different sizes, types and ages to compete with the fairest ratings possible.

The ORR is an objective rule. Its ratings are based on full measurement of all the speed-related features of sailboats and on a Velocity Prediction Program (VPP) that calculates the speed potential of each boat at any combination of wind speed and course direction. The VPP is a set of algorithms developed through systematic research that use fundamental scientific methods.

ORR is intended to be a non-typeforming measurement rule that fairly rates properly designed and prepared yachts which are equipped for offshore racing. It must be clearly understood by all who use ORR that it is not a development rule and therefore is not intended for sailors who are looking to "beat" the rule. In order to discourage attempts to design yachts "to the rule", the algorithms of the VPP are non-public. ORR will be updated on a regular basis to stay ahead of design developments.

The ORR Rulebook provides details about measurement, restrictions, ratings and everything else required to race under the ORR. Owners, sailors, designers, sail-makers and builders should consult the rulebook to prepare and race their boats. This Quick Start Guide provides an overview to help owners understand what they need to do to race under ORR.

1. Scope of Rule

The ORR is intended to rate a broad diversity of sailing yachts but limits are imposed either to ensure reasonably close racing or because there is insufficient science. For example, at present ORR does not rate multi-hull yachts or kite sails.

2. Certificates

Valid certificates, issued by US SAILING, are required for racing under ORR. This guide, and the rulebook, will help owners through the process of measurement and certification.

3. Getting Started

The ORR requires a full description of the geometry of hull, rig, and sails; how the boat sits in the water (to get length, weight, wetted area, etc.) and the stability of the boat (resistance to heeling over.)

Owners should contact US SAILING who will provide necessary information and refer them to a trained and certified measurer for their geographic area. The owner should familiarize himself with this guide and contact the measurer to begin the measurement process.

For boats with a valid IMS or fully measured valid AMERICAP certificate, that is sufficient information for a "Fully Measured" ORR certificate. For boats with a valid AMERICAP certificate that was issued using less than full measurements or declared input data, this information is sufficient for a "Partial Measurement" ORR certificate.
Reference: Rule 1.03

4. Hull Measurement Ashore

The owner is responsible for preparing the boat for measurement ashore. The surface of the hull will be surveyed with an instrument that provides the detailed description necessary for the calculations in the VPP.
Reference: Rule 3.02.1

If the boat has a sister ship that has been fully measured, the requirement for hull surveying may be waived by the chief measurer. Hull surveying may also be waived if the designer of the boat supplies the "lines" in a suitable electronic format. In the latter case, measurement checks will be conducted.
Reference: Rule 3.02.1.c

5. Measurement Afloat

The owner is responsible for preparing the boat for measurement afloat. This means following the instructions for Measurement Trim, basically a list of what shall and shall not be on board. The measurer will measure the freeboards of the boat and conduct an inclining test to establish the stability.
Reference: Rule 3.02.2

Fully measured boats bear the notation "FULL MEASUREMENT". If the boat has a sister ship that was measured in-water, those measurements may be used, subject to a review by ORR administration. In such a case the resulting ORR certificate will be labeled "PARTIAL MEASUREMENT".
Reference: Rule 1.03

Please be aware that some regattas may require FULL MEASUREMENT certificates.

6. Rig and Sail Measurement

The owner is responsible for declaring to the measurer all spars and sails that he proposes to carry on the yacht and make them available for measurement. The dimensions of the principal elements of the rig: masts, booms, poles, sprits and sail attachment points shall be measured. The dimensions of the sails will be measured to derive the sail areas used for rating calculation.
Reference: Rule 3.02.3, Part IX - RIG, Part XX - SAILS

7. Configuration Changes

If there are changes to the canoe body, the appendages, the rig, the sails and/or equipment carried on board, or to anything that might change the boat's rating the owner is responsible to declare these changes to the rating authority.
Reference: Rule 3.03.1

8. Stability Requirements

Participation in ORR races may be restricted on the basis of the Stability Index, derived from the boats LPS, maximum beam, displacement (weight) and sailing length. *Reference: Rule 2.02.1*

For boats with moveable ballast, participation in ORR races may be restricted on the basis of the Ballast Leeward Recovery Index (BLRI). The BLRI represents the ability of a boat to recover from a knockdown with the moveable ballast located to leeward. *Reference: Rule 2.02.2*

9. Restrictions While Racing

The purpose is to prevent boats being raced in hull, rig and/or sail configurations that are different from how the boat was measured and rated or are out of the scope of what the ORR rule permits. *Reference: PART IV*

Specific examples include:

- Movement of ballast, fixtures and accommodation
- Running the engine for propulsion
- Changes in fuel and water tankage beyond normal use
- Use of stored energy in ways other than those explicitly permitted
- Rotating masts
- Altering the location of the mast step
- Trim and use of sails not consistent with how they were measured and rated
- Changes to standing rigging is not permitted while racing

CONTENTS

PART I	GENERAL	
1.01	Administration	9
1.02	Rule Philosophy	9
1.03	ORR Certificates	9
1.04	Measurement	10
1.05	Rule Dates	10
PART II	GENERAL LIMITS & EXCLUSIONS	
2.01	Hull Type	12
2.02	Stability	12
2.03	Appendages	13
2.04	Speed Under Power	14
2.05	Propeller Shaft	14
2.06	Weights and Ballast	14
PART III	OWNER'S RESPONSIBILITIES	
3.01	Owner's Signature	14
3.02	Responsibilities for Measurement	15
3.03	Responsibilities after Measurement	16
PART IV	ORR RESTRICTIONS WHILE RACING	
4.01	Bloopers	17
4.02	Crew Weight Limit	17
4.03	Crew Limitations on Professionals	17
4.04	Shipping, Unshipping or Shift of Ballast, Fixtures, Accommodations	17
4.05	Movement from Stowage While Racing	18
4.06	Engine and Propeller	18
4.07	Drop Keels and Movable Appendages	18
4.08	Tankage	18
4.09	Energy Storage	18
PART V	PREPARATION FOR MEASUREMENT	
5.01	Hull Measurement Ashore	19
5.02	Measurement Afloat	19
5.03	Mast and Rig Weight	21

PART VI	HULL	
6.01	Principle of Hull Measurement.....	21
6.02	Hull Offset File	21
6.03	Remeasurement	21
6.04	Length Overall (LOA)	21
6.05	Maximum Beam (MB).....	22
6.06	Definitions of Keels	22
6.07	Limitations on Centerboards	22
6.08	Measurement Trim	22
6.09	Sailing Trim.....	23
6.10	Sailing Length (L).	23
6.11	Displacement (DSPM & DSPS).	23
6.12	Wetted Surface (WSS).	23
6.13	Maximum Draft Including Keel (DHK).	23
6.14	Maximum Draft Adjusted for Centerboard (DHKA)	23
PART VII	PROPELLER	
7.01	General Requirements.....	23
7.02	Propeller Types	23
7.03	Installation Types	24
PART VIII	STABILITY & PITCH GYRADIUS	
8.01	Inclining Tests.....	24
8.02	Pendulum Length (PL)	25
8.03	Weight Distance (WD)	25
8.04	Pendulum Deflections (PD).....	25
8.05	Weights (W)	25
8.06	Inclining Slope (SLOPE)	26
8.07	Righting Moment (RM).....	26
8.08	Righting Moment Corrected (RMC)	26
8.09	Righting Moment per Degree in Sailing Trim at 2 Degrees.....	26
8.10	Righting Moments by Heel Angle.....	26
8.11	Crew Weight (CW), Base Crew Weight (BCW).....	26
8.12	Declared Crew Weight (DCW).....	26
8.13	Elements of Pitch Gyradius	27
8.14	Assessment of Pitch Gyradius	28
PART IX	RIG	
9.01	Rig Restrictions	29
9.02	Sail and Rig Measurement	30
9.03	Painted Measurement Bands	30
9.04	Base of Foretriangle (J).....	30
9.05	Spinnaker Pole and Spinnaker Tack Point (SPL & TPS).....	30
9.06	Mast Measurements.....	31
9.07	Mainsail Hoist (P)	32
9.08	Height of Deck	32
9.09	Boom above Sheerline (BAS)	32
9.10	Foot of Mainsail (E & BAL).....	32

9.11	Boom Diameter (BD)	33
9.12	Rigging Plan.....	33
9.13	Chainplate Width (CPW).....	34
9.14	Rig Weight and Center of Gravity (MWT, MCG & WB)	34
9.15	Height of Mizzen Mast (IY)	34
9.16	Mizzen Mast Diameters and Taper Length.....	35
9.17	Mizzen Hoist (PY)	35
9.18	Boom above Sheerline (BASY)	35
9.19	Foot of Mizzen (EY, BALY)	35
9.20	Mizzen Boom Diameter (BDY).....	35
9.21	Distance between Masts (EB)	35
PART X	SAILS	
10.01	Rig Restrictions	36
10.02	Sail Inventory.....	36
10.03	Trimming of Sails	36
10.04	Double Luffed Sails	37
10.05	Restrictions on Setting and Sheeting of Jibs	37
10.06	Restrictions on Setting and Sheeting of Spinnakers.....	37
10.07	Restrictions on Setting and Sheeting of Mainsails	38
10.08	Restrictions on Setting and Sheeting of Mizzen Staysails	38
10.09	Tension and Wrinkles in Sails	38
10.10	Measurement Points at Corners of Sails	39
10.11	Definition of Headsails	39
10.12	Longest Perpendicular of Jibs (LPG)	39
10.13	Jib Girths and Jib Roach (JR)	40
10.14	Forestay Perpendicular (FSP).....	40
10.15	Longest Luff of Jibs (JL).....	40
10.16	Jib Limitations	40
10.17	Symmetric Spinnakers.....	41
10.18	Asymmetric Spinnakers	41
10.19	Spinnaker Headboard (HBS)	41
10.20	Spinnaker Maximum Width (SMW)	41
10.21	Spinnaker Luff and Leech (SL & ASL)	42
10.22	Spinnaker Foot Length (SF & ASF)	42
10.23	Asymmetric Spinnaker Mid Girth Length (AMG)	42
10.24	Measurements for Spinnaker Area.....	42
10.25	Spinnaker Limitations.....	42
10.26	Mainsail Head.....	43
10.27	Mainsail Clew	43
10.28	Mainsail Cross Widths	43
10.29	Mainsail Mid Point of Leech	43
10.30	Mainsail Headboard (HB).....	43
10.31	Top Batten Upper Limit	44
10.32	Mainsail Girths (MGT, MGU, MGM, & MGL).....	44
10.33	Mainsail Weight (MSW)	45
10.34	Batten Adjustment.....	45
10.35	Mizzen Headboard (HBY).....	45
10.36	Mizzen Top Batten upper limit	45
10.37	Mizzen Girths (MGTY, MGUY, MGY & MGLY).....	45
10.38	Mizzen Batten Adjustment.....	45
10.39	Mizzen Staysail Foot (YSF).....	45

10.40	Mizzen Staysail Depth (YSD).....	45
10.41	Mizzen Staysail Mid Girth (YSMG).....	46
10.42	Sail Plan Rated Areas	46
10.43	Foretriangle Height (IM).....	46
10.44	Longest Perpendicular of Jibs, Rated (LP)	46
10.45	Rated Limits.....	47
10.46	Aerodynamic Drag of Masts.....	47
10.47	Aerodynamic Drag of Rigging and Spreaders.....	47
10.48	Effective Height of Mainmast (EHM)	47
10.49	Diameter of Mainmast (EDM).....	48
10.50	Effective Height of Mizzenmast (EHMY)	48
10.51	Effective Diameter of Mizzenmast (EDMY)	48
INDEX	49
APPENDIX 1	ORR RATING CERTIFICATE	53
APPENDIX 2	MEASUREMENT CONDITION CHECK LIST & INVENTORY	54
APPENDIX 3	VARIOUS SHEER POINT DIAGRAMS.....	55
APPENDIX 4	RULES AND PROCEDURES FOR RACE ADMINISTRATION	56
APPENDIX 5	ADMINISTRATIVE RATING PROTESTS.....	58
APPENDIX 6	DYNAMIC & AGE ALLOWANCES	60
APPENDIX 7	WATER BALLAST & SPECIAL APPENDAGES.....	61

PART I – GENERAL

1.01 Administration.

The Offshore Racing Association (herein denoted as ORA) is the authority for administration of the Offshore Racing Rule (ORR). The ORA is responsible for the development and promotion of ORR and, in collaboration with its national sailing authority US SAILING, implementation of the rule.

1.02 Rule Philosophy.

The ORR predicts relative time allowances between boats to permit boats of different sizes, types and ages to compete with the fairest ratings possible.

The ORR is an objective rule. Its ratings are based on full measurement of all the speed-related features of sailboats and on a Velocity Prediction Program (VPP) that calculates the speed potential of each boat at any combination of wind speed and course direction. The VPP is a set of algorithms developed through systematic research that use fundamental scientific methods.

ORR is intended to be a non-typeforming measurement rule that fairly rates properly designed and prepared yachts which are equipped for offshore racing. It must be clearly understood by all who use ORR that it is not a development rule and therefore is not intended for sailors who are looking to "beat" the rule. In order to discourage attempts to design yachts "to the rule", the algorithms of the VPP are non-public. ORR will be updated on a regular basis to stay ahead of design developments.

1.03 ORR Certificates

Valid certificates are required for racing within ORR. The ORR certificate will provide the most basic information about a boat, its measurements, and its ratings. Certificates are issued by US SAILING.

If a boat has a valid IMS or fully measured valid AMERICAP certificate, that is sufficient measurement information for an ORR certificate. Expired IMS or AMERICAP certificates may be acceptable pending approval of the Chief Measurer.

There are two types of certificate:

1.03.1 Full Measurement.

ORR certificates issued on the basis of full ORR measurement shall bear the notation "FULL MEASUREMENT" at the top of the certificate.

1.03.2 Declared Measurement.

Any certificate which is based on less than full ORR measurement shall bear the notation "PARTIAL MEASUREMENT" at the top of the certificate.

1.04 Measurement

Boats shall be measured by official measurers certified by US SAILING. Hulls and appendages are measured by either of two methods, both of which are accepted for "FULL MEASUREMENT" certificates:

- Survey using an HMI, Hull Measuring Instrument, or by using a laser scanning device approved by ORA and administered by US SAILING.
- Designer supplied lines, in an ORA approved format, that will be checked for validity by an ORR authorized measurer following procedures specified by ORA and US SAILING.

Rig dimensions shall be measured by an official measurer.

Sails can be measured by a US SAILING trained and certified employee of a sail loft. Standard certificates will be provided to US SAILING for all sails. These are subject to validation by an official measurer.

Boats will be measured in-water, subject to the conditions and requirements specified by ORR Measurement Trim. Accommodation may be made for boats that are set-up in trim conditions specified by other rules. Measurements will include port and starboard freeboards at fore and aft locations and an inclining measurement to determine the vertical center of gravity of the boat.

1.05 Rule Dates.

All rule dates shall be recorded and maintained on the Rating Certificate.

1.05.1 Age Date. This date shall be the month and year of launching which shall be defined as date of first inclining unless the owner provides documentary evidence that the yacht was launched at an earlier date, completed and equipped for sailing.

1.05.2 Series Date. US SAILING may authorize a Series Date, being earlier than the age date, for an unmodified series-produced yacht if it is satisfied that the yachts of the series are built to close tolerances in moulds or jigs. The Series Date shall be the Age Date of the earliest yacht of the series. Series Dates shall be based on boats of a series built in the production moulds or jigs and not on prototypes which were not built in the same moulds or jigs. The Series Date may be changed as a result of a boat being modified from the original model, or conversely built on an older design.

1.05.3 Hull Modifications. Hull modifications shall require plan review by the chief measurer and will require hull re-measurement. Modifications except as permitted below shall result in the assignment of a new Age Date which shall be as defined in 1 above, following the completion of the modifications. The following are permitted without a change of Age Date:

- Changes that do not affect the canoe body.
- New appendages or fairing of existing ones.
- Removal of bumps outside the canoe body outer skin.
- Filling of hollows (e.g., in the IOR after girth area).

- Forward or aft extensions or reductions of the fair surface of the hull, limited to modifications only within 0.10*LOA of the forward and/or aft end(s) of LOA.

The total of modifications to the canoe body surface shall not exceed 20% of the total surface prior to modification as determined by the Measurer. After review by the Revalidation Authority, the Measurer shall verify on the yacht the boundaries of the proposed changes before and after the work.

1.05.4 Measurement Inventory (Flotation) Date. Measurement Inventory Date shall be the date of the most recent occasion on which the yacht was measured afloat.

1.05.5 Measured Date. Measured Date shall be the date that the most recent measurement was completed.

1.05.6 Issued Date. Issued Date shall be the date that the current certificate was issued from the Rating Office

PART II – GENERAL LIMITS AND EXCLUSIONS

2.01 Hull Type

This rule is intended to be used for the rating of monohull yachts only. Hulls in which the canoe body depth in any section decreases towards the center line shall not be rated under this rule.

2.02 Stability

2.02.1 Stability Index: A yacht's eligibility for entry in ORR races of ORC Special Regulations Categories 0, 1 or 2 may be limited on the basis of her Stability Index, at the option of the race organizer.

$$\text{Stability Index} = \text{LPS} + \text{Capsize Increment (CI)} + \text{Size Increment (SI)}$$

Where, in imperial units:

LPS = Limit of Positive Stability, the heel angle at which the righting arm is zero.

$$\text{CI} = 18.75 * (2.0 - \text{MB} / (\text{DSPM} / 64)^{.3333})$$

$$\text{SI} = (((12.0 * (\text{DSPM} / 64)^{.3333} + \text{LSM0}) / 3.0) - 30.0) / 3.0$$

CI shall not be taken as greater than 5.0 nor less than -5.0.

SI shall not be taken as greater than 10.0.

NOTE: Stability Index for water ballast yachts is calculated with ballast tankage full on one side, empty on the other and for canting keel yachts with the keel fully canted.

The following table provides the recommended minimum stability index for various categories of races:

<u>Offshore Race Category</u>	<u>Minimum Stability Index</u>
0	120
1	115
2	110

2.02.2 Ballast-Leeward Recovery Index (BLRI). For a yacht incorporating water ballast or a canting keel, eligibility for entry in ORR races of Special Regulations Categories 0, 1 or 2 may be limited by the race organizer on the basis of Ballast-Leeward Recovery Index (BLRI) as recommended below.

- a) The BLR Index represents such a yacht's relative ability to recover from a knock down with sails aback, i.e., knocked down with all water ballast or canting keel to leeward. BLR Index is calculated as follows:

$$\text{BLR Index} = (\text{RA90} * \text{DSPS} / (2 * \text{SA} * \text{CE})) * 0.333 + 0.5$$

Where, in metric units:

RA90 is the righting arm, 90 degrees heel, ORR Sailing Trim.

DSPS is the ORR Displacement in Sailing Trim.

SA is the geometric area of the ORR rated sailplan, i.e., mainsail and foretriangle.

CE is the Center of Effort of the ORR rated sailplan, i.e., mainsail and foretriangle.
(all taken with full leeward cant or leeward ballast tankage full, windward empty)

- b) The Limits for minimum BLR Index are specified according to Special Regulations Race Category (0, 1 & 2) and vary with ORR sailing length in Sailing Trim. They are therefore displayed on the Certificate as SRCat0 Minimum and SRCat1&2 Minimum. The limits are calculated as follows.

SR Category 0: Minimum = $0.90 + 0.007*(LSM1 - 5)$

SR Categories 1 & 2: Minimum = $0.75 + 0.007*(LSM1 - 5)$

2.03 Appendages

Yachts may race under ORR subject to the following limitations on appendages:

- 2.03.1** Keel foils must be solid in profile and have an attachment to the hull at the yacht centerline.
- 2.03.2** The keel may have an end plate, winglets, a midline centerboard and/or a trim tab.
- 2.03.3** The keel may be canting (keel rotating around root hinged to hull at yacht centerline) and the boat will then be subject to restrictions pertaining to yachts with moveable ballast canting keels.
- 2.03.4** Keels may have trim tabs. The axis of rotation of the trim tab shall be in the center plane of the keel.
- 2.03.5** The yacht may have a skeg, one or two normal rigid-surface midline rudders or off-midline, coupled, non-retractable twin rudders.
- 2.03.6** Off centerline dagger boards are permitted.
- 2.03.6** The yacht may have a bona fide propeller installation and the usual instrument transducers.
- 2.03.7** Centerboard and daggerboard movement is restricted to motion up or down either in a straight line or around a single fixed pivot. Excluded are:
- 2.03.7.1** Centerboards arranged for fore and aft motion except the motion resulting from conventional pivoting around a pin located in the conventional position.
- 2.03.7.2** Centerboard openings or slots arranged to cause or permit angular motion of the centerboard in a sense to alter the angle of attack while sailing and any other schemes for achieving the same result.
- 2.03.7.3** Conventional flexible centerboard slot fairing closures are permitted.
- 2.03.8** Conventional flexible fairings over the rudderpost are permitted.

2.04 Speed Under Power

Yachts shall be capable of speed under power with racing propeller in smooth water and without assistance of wind of, in knots, not less than $1.811 * L^{0.5}$ where L is the ORR L (see 6.10) in meters ($L^{0.5}$ where L is in feet) to qualify for any Propeller Installation Projected Area (**PIPA**) greater than zero.

2.05 Propeller Shaft

The propeller shaft exposed to water flow is circular in cross section.

2.06 Weights and Ballast

2.06.1 Except for the stability and trim ballast of the hull, all weights measured under this rule shall be the true weight associated with proper structural engineering and no weights shall be artificially increased through ballasting.

2.06.2 No yacht shall be rated under ORR if any material having a density greater than that of lead (specific gravity = 11.35) is used as ballast in any form or location on or within the yacht.

PART III – OWNERS RESPONSIBILITIES

3.01 Owner's Signature.

Before any certificate under this rule is valid it must be signed by the owner of the yacht. The name of the individual who signs the Certificate shall also be printed on the Certificate. By this signature the owner signifies that he or she understands the owner's responsibilities under all parts of the ORR Rule, a copy of which shall be aboard while racing.

Responsibility for Compliance - The owner shall have the primary responsibility for ensuring compliance with the ORR rules.

Owner's responsibilities are divided into three categories.

- Owner's responsibilities prior to and during measurement.
- Owner's responsibilities after measurement.
- Owner's responsibilities while racing.

3.02 Owner's Responsibilities: Measurement.

The owner is responsible for arranging measurement with US SAILING.

3.02.1 Measurement Ashore.

- a) He shall present the yacht for measurement ashore in an accessible location, clear of obstructions, properly chocked and leveled (see 5.01 for details).
- b) If the yacht is of a class for which sister ship hull measurements are available, hull measurement may not be required. The owner shall inform the measurer of any modifications that have been made so that the measurer may determine whether, and to what extent, the hull standard applies to the yacht. The owner shall make the yacht available ashore for the checking of any measurements that the measurer may require.
- c) If the yacht is of a class for which designer lines hull measurements have been validated, full hull measurement may not be required. The owner shall inform the measurer of any modifications that have been made so that the measurer may determine whether, and to what extent, the designer lines hull standard applies to the yacht. Certain minimum measurement verification is required. This includes measurement of the as-built freeboard to centerline of the canoe body plus any additional measurements as determined by US SAILING. The owner shall make the yacht available ashore for the checking of these measurements or any others that the measurer may require.

3.02.2 Measurement Afloat

- a) He shall on another occasion make the yacht available at a suitable location agreed with the measurer so that flotation measurements may be taken.
- b) He is responsible for preparing the yacht in measurement trim as specified in 502.2. He shall declare to the measurer the weight and location of all ballast, except that contained in the external keel or centerboard, and all other items mentioned in 402.2(h). He shall, together with the measurer, complete and initial the Measurement Condition Check List & Inventory (See Appendix 2).
- c) If the yacht is fitted with a drop keel and/or a movable appendage which is to be locked for measurement and racing under 6.06.3, the owner shall be responsible for ensuring that a positive locking and locating device is fitted at the time of measurement. If the device is to be freed for cruising or at other times when the yacht is not racing the device must be of a form that will positively locate and retain the keel in one predetermined position.

3.02.3 Sail Areas The owner is responsible for declaring to the measurer all spars and sails that he proposes to carry on the yacht and the location in which he proposes to set them, so that they may be properly measured

3.02.4 Hull Construction and Spar Material The owner is responsible for declaring to the measurer the type of hull construction and material of which the hull and spars are built.

3.03 Owner's Responsibilities after Measurement.

3.03.1 It is the owner's responsibility to declare to the rating authority any changes made to the yacht, its rig, or its equipment which could change any of its measurements under the rule.

Such changes could be:

- a) Changes of ballast in amount or location or configuration.
- b) Change of tankage, fixed or portable, in size or location.
- c) Any changes in the engine and/or propeller installation.
- d) Addition, removal or change of location of gear or equipment, or structural alteration to the hull, that affect the trim or flotation of the yacht.
- e) Movement of any measurement bands used in sail area measurement, or any changes in spars, spar location or headstay position.
- f) The owner shall be responsible for ensuring that all sails other than storm sails have been measured by an official measurer and do not contravene the values stated or permitted for them on the Rating Certificate.
- g) Changes to the shape of the yacht's hull and/or appendages. Note that changes to the hull may cause the yacht to lose the benefits of age under the rules (See Appendix 6).
- h) Changes to spars or standing rigging configuration, including elements of rigging identified as adjustable while racing.
- i) Changes to the Elements of Pitch Gyradius (see 8.13) including hull, deck and appendage construction, spars, accommodation and rig configuration, etc.

3.03.2 One-Design Rating. Where a yacht has a One-Design Rating (see Part XI) it is the owner's responsibility to ensure that the yacht is at all times maintained within the class rules. The class rules shall always be aboard the yacht. Should any changes be made to the yacht that are not permitted within the class rules the owner shall inform the Rating Authority and the ORR Certificate becomes invalid immediately.

PART IV – ORR RESTRICTIONS WHILE RACING

The owner is responsible for ensuring that the ORR Rule Book is aboard the yacht and that all members of the crew fully understand and comply with the limitations which apply while racing.

4.01 Bloopers.

Bloopers are prohibited. When a spinnaker is set, no jib shall be tacked in such a way as to cause or permit the luff or forward edge of that sail to lie outside of the spinnaker or spinnaker sheet and, when a spinnaker is set, no sail shall be sheeted to the main boom except the spinnaker itself.

4.02 Crew Weight Limit.

The owner shall be responsible for insuring that the weight of the crew, weighed in light street clothes, on board the yacht for any race does not exceed the Maximum Crew Weight printed on the Rating Certificate and any excess shall automatically suspend validity of the Certificate.

4.03 Crew Limitations on Professionals. (Optional)

For those race organizations that wish to offer events with limitations on the number of professionals on board while racing, the following option is offered. This paragraph is not in force unless it is specifically included in the Notice of Race by the race organizer.

4.03.1 Competitor Groups. Three competitor Groups shall be defined as set forth in the ISAF (International Sailing Federation) Sailor Classification Code; i.e. Group 1 (amateur), Group 3 (professional), Group 2 (anyone not Group 1 or Group 3). For more information go to www.sailing.org/classification/classificationcode.asp.

4.03.2 Yacht Owners. For the purpose of the regulations below, an Owner is defined as one who, to the satisfaction of the Race Committee, demonstrates at least a one-third partner interest in the ownership of the yacht on which the person competes.

4.03.3 Limitations. Group 2 and Group 3 competitors shall be limited as follows:

- a) Including those of Owner status, the combined number of Group 2 and Group 3 competitors aboard a yacht while racing shall not exceed the limits as given in the table below.

<u>LOA (feet)</u>	<u>LOA (meters)</u>	<u>Limit</u>	<u>LOA (feet)</u>	<u>LOA (meters)</u>	<u>Limit</u>
26.0 - 34.99	7.925 - 10.665	2	56.0 - 62.99	17.069 - 19.200	6
35.0 - 41.99	10.668 - 12.799	3	63.0 - 69.99	19.203 - 21.333	7
42.0 - 48.99	12.802 - 14.932	4	70.0 - 76.99	21.336 - 23.467	8
49.0 - 55.99	14.935 - 17.066	5	77.0 - 100.00	23.470 - 30.480	9

- b) Except for Owners and except for emergencies involving the safety of the yacht or crew, Group 2 and Group 3 competitors are prohibited from steering while racing.

4.04 Shipping, Unshipping or Shifting of Ballast, Fixtures and Accommodation.

Note: See also ORR Appendix 7 exclusion for yachts rated with water ballast or canting keel.

The removal for racing of fixtures and items of accommodation which were aboard for in-water measurement or identified as Elements of Pitch Gyradius is not permitted.

Attention is called to Section 51 of the RRS - Moving Ballast: "All movable ballast shall be properly stowed, and water, dead weight or ballast shall not be moved for the purpose of changing trim or stability. Floorboards, bulkheads, doors, stairs and water tanks shall be left in place and all cabin fixtures kept on board".

Note that unwarranted quantities of stores, including fuel and water, shall be considered as ballast under this rule.

4.05 Movement from Stowage While Racing.

Portable equipment, gear, sails and stores may only be moved from stowage for use in their primary purpose. Stowage in this respect is the position for any item of equipment or stores, to be maintained for the duration of a race or series, when such item is not in use for its primary purpose. Note: Moving sails or equipment with the intention of improving performance is prohibited and shall be considered a contravention of RRS 51.

4.06 Engine and Propeller.

The owner is responsible for ensuring that when the engine is run for any purpose the propeller does not rotate.

4.07 Drop Keels and Movable Appendages.

The owner is responsible for ensuring that any locating device for a locked drop keel or movable appendage, called for by the rule, is at all times in place while racing. If for any reason such a device is removed during a race the owner shall declare the fact to the race committee and withdraw on completion of the race.

4.08 Tankage.

Tanks which are always to be empty when racing may be declared as such and shall be empty at the time of measurement providing each declaration is entered on the rating certificate and the owner accepts responsibility that these limitations will be observed. Voids in the keel or any other appendage shall be declared at the time of measurement and shall be treated as tankage.

4.09 Energy Storage.

Other than bilge pumps, no device, unless permitted under RRS 52 Manual Power, may be used while racing which derives assistance from energy stored to do work. However, refer to the ORR Appendix 7 exclusion to this for yachts rated with water ballast or canting keel.

This rule may be modified by race organizers through their Notice of Race to permit the use of stored energy for winches, furlers and autopilots.

PART V – PREPARATION FOR MEASUREMENT

FREEBOARD MEASUREMENT PROCEDURE

To secure an accurate and fair measurement, it is necessary to have close co-operation between owner and Measurer. It is desirable, therefore, that the owner be reasonably familiar with the requirements below.

5.01 Hull Measurement Ashore.

The hull and appendage measurements (Part VI) and propeller installation measurements (Part VII) shall be taken ashore with the yacht exactly level athwartships and approximately in the same longitudinal trim which it might reasonably be expected to assume when afloat in measurement trim.

5.01.1 The yacht shall be presented for measurement ashore in an accessible location, clear of obstructions (see 5.01.2 below), properly and firmly chocked and leveled as above. The weight of the yacht shall rest on the keel except as is necessary to chock the hull as above. A centerboard locked to prevent movement for racing shall be in its locked position and measured as a keel. Rigging shall be slack. All appendages shall be fitted and any fairings, as permitted under 2.03.7.3, shall be in place.

5.01.2 The hull will be surveyed with a Hull Measuring Instrument (HMI) or approved laser scanner (LS). In either case the machine will be set abeam the hull and relocated fore and aft along the length of the hull, both port and starboard. Measurement points will be recorded from the deepest part of the hull or appendage up to the sheer line.

5.01.3 Clearance for the operation of the HMI or LS must be provided around the hull, in the construction of the cradle and the means of supporting the keel. Nominally, clear areas (including the ground surface) are required 1.5m (4 ft) forward and abaft the hull and 2.0m (6 ft) on either side of the hull. With some HMIs the minima are 60cm (2 ft) forward and abaft the hull and 1m (3 ft) on either side. The Measurer should be consulted for details. Cradle support struts and athwartships cradle bulkheads can usually be accommodated, but longitudinal cradle bulkheads and keel support channels prohibit reaching required measurement points.

5.01.4 Sheer Point. At any measured station, the sheer point is the highest point, in the vicinity of the hull/deck join, where a tangent at 45 degrees can be rested on the hull. See Appendix 3.

5.01.5 Sheer Line. The sheer line is defined as the line passing through the sheer points defined above.

5.02 Measurement Afloat.

Inclined stability and freeboards shall be measured on one occasion with the yacht afloat in measurement trim (see 5.02.2 below). Normally, the yacht's spinnaker pole(s) will be required for suspending the inclining weights (see Part VIII) and a dinghy or raft must be available for use by the Measurer. The owner or the owner's Authorized Representative (see Measurement Inventory Form, Appendix 2) must be present for flotation measurement.

5.02.1 Specific Gravity (SG): The specific gravity of the water shall be measured at this time and recorded as SG. The water shall be sampled from a level 0.3m (one foot) below the surface.

5.02.2 Measurement Trim: The owner or his representative will put the yacht in measurement trim by following the procedure defined below. The Measurement Inventory set out in Appendix 2 shall be used to ensure and record compliance with the requirements. No substitutions are permitted during measurement afloat.

- a) The yacht shall be completed and equipped for sailing.
 1. All standing rigging and related fittings used while racing will be attached in their normal positions. Running rigging forward of the mast and all halyards and lifts shall be taken to the foot of the mast and hauled tight. All other pieces of running rigging abaft the mast shall be taken to their aftermost position and hauled tight. All halyard tails shall be taken to their normal working positions. If the halyard weight varies significantly along its length, the tail shall be on the cabin floor for the inclining experiment, with the halyard fully hoisted, attached to a light messenger. A halyard may be used as a topping lift.
 2. One set of sheets and guys and any running rigging not carried permanently on spars and other portable deck gear used in sailing the yacht shall be stowed just abaft the mast on the cabin sole.
- b) Main and mizzen booms shall be secured at the low points of respectively P (see 9.07) and PY (see 9.17). From 1/1/2002, no spinnaker pole shall be aboard while measuring freeboards. Masts shall be raked aft to the limit of their adjustment. Where this limit is forward of the vertical the mast shall be set vertical.
- c) No sails shall be aboard.
- d) All mattresses, cushions, and pillows must be aboard during measurement and shall be stowed in their normal bunks. Safety, navigational and cooking equipment shall be aboard and all portable gear normally stowed aft of the foremost mast shall be in its normal position for racing. All portable gear normally stowed forward shall be placed abaft the foremost mast on the cabin sole for measurement, unless otherwise specified in this Rule.
- e) No clothing, bedding, food, stores, dinghy, man-overboard pole or liferafts shall be on board.
- f) Additional equipment on board during measurement shall be itemised in the Measurement Inventory.
- g) The bow of the yacht shall not be depressed through lying to a mooring.
- h) Ballast shall be fixed below the cabin sole, or as low as possible at any station and sealed to the hull structure to prevent movement. The yacht shall not be ballasted in such a manner as to induce list. Anchors and chain shall be secured in clearly marked stowage. Yachts shall be measured with at least one anchor. The batteries shall be secured in their proper stowage. The weights of these items and their distances from the stem will be recorded on the Measurement Inventory. Anchor rope shall not be forward of the foremost mast.
- i) All tanks shall be empty at the time of measurement, with the exception that the fuel tank can contain a small amount sufficient only for maneuvering.
- j) Hydraulic systems including hydraulic tanks shall be full for measurement and shall remain full when racing.

- k) Bilges and other areas where water may collect shall be dry. There must be no effort to artificially moisten decks, rig, equipment or gear.
- l) No one shall be on board while flotation measurements are being taken.
- m) Centerboard(s) and drop keels shall be fully raised. If any drop keel or movable appendage is to be locked when racing it shall be so locked for measurement and the locking device shall be in place.
- n) If an outboard motor, where it is the yacht's engine, is to be carried when racing it SHALL BE provided with a proper locker and/or mounting bracket. It shall be in this stowage at the time of measurement and at all times when racing.

5.03 Mast and Rig Weight.

Assessment of pitch gyradius (Part VIII) requires measurement and/or the classification of various features of the yacht. Masts which qualify as carbon shall be measured for total rig weight and vertical center of gravity, prepared as specified under 9.14. Other elements of pitch gyradius require counting of spreaders, jumpers and runners, the classification of hull construction, rudder construction and accommodation.

PART VI – HULL

HULL MEASUREMENT

6.01 Principle of Hull Measurement.

It is the principle of hull measurement under the ORR that the "lines" of the hull and appendages are recorded in considerable detail so as to yield, in combination with measurements afloat, hydrostatic data sufficiently accurate for rating purposes.

6.02 Hull Offset File.

The Hull Offset File as processed by the ORA/rating authority shall define the yacht's hull for the purpose of calculating a valid ORR Certificate until such time as there may be a change to the actual hull (including appendages).

6.03 Remeasurement.

A hull which has been modified will normally require hull re-measurement. A hull which has not changed shall not be re-measured and processed except where the Rating Authority is satisfied that reasonable evidence of error exists.

6.04 Length Overall (LOA).

The length overall of a yacht will be measured to include the whole hull, but not spars or projections fixed to the hull such as chainplates, bowsprits, boomkins, pulpits, etc.

6.05 Maximum Beam (MB).

The maximum beam of the boat as taken from the measured offset file.

6.06 Definitions of Keels.

A yacht's keel configuration shall be determined by its characteristics and shall be classified as one of the following.

6.06.1 Fixed Keel. A yacht shall be classified as fixed keel when no part of the keel is adjustable when racing so as to alter the yacht's maximum draft.

6.06.2 Centerboard. A yacht shall be classified as centerboard when she is fitted with a centerboard(s) and/or a daggerboard(s) which can and may be moved when racing to modify the yacht's total draft. The total weight in air of such boards shall be less than $0.05 \times \text{DSPM}$.

6.06.3 Drop Keel. A yacht shall be classified as drop keel when she is fitted with a board or boards which can and may be moved when racing to modify the yacht's total draft and where the total weight in air of such board(s) is equal to or more than $0.05 \times \text{DSPM}$.

6.06.4 Wing Keel. A yacht shall be classified as wing keel if the keel meets specific criteria in the Guide to ORR Measurement.

6.07 Limitations on Centerboards

6.07.1 The movement of a centerboard or drop keel while racing shall be restricted to one of the following:

- a) Straight extension or retraction as in a dagger board.
- b) Extension about a single fixed pivot.

6.07.2 The longitudinal movement of the center of gravity of a Drop Keel when it is being raised or lowered (CBLD) shall not exceed $0.06 \times L$.

6.07.3 A yacht equipped with a centerboard or drop keel which fails for any reason to fulfill the requirement of 607.1 and 607.2 above, shall be given dispensation if the board or keel can be fixed in a predetermined position and shall be so fixed both for measurement and at all times when racing. Such a yacht shall be classified and measured as a fixed keel yacht for rating purposes.

HULL DERIVED CHARACTERISTICS

6.08 Measurement Trim.

The yacht is measured afloat in a convenient location according to the rules for condition of loading as set forth in 5.02.2 for the purpose of defining "local" measurement trim. At the time of flotation measurement, the local Specific Gravity is measured and recorded as SG.

Measurement Trim for rating calculations is the trim derived in the VPP by converting flotation at local SG to a normalized flotation at a standard SG equal to 1.02528 (nominal seawater).

6.09 Sailing Trim.

Sailing Trim shall be the plane of flotation derived from Measurement Trim by the addition of weight to represent a crew (8.11) and a practical minimum of gear.

6.10 Sailing Length (L).

The Sailing Length (L) is an effective sailing length which takes into account the hull form at the ends of the yacht, both above and below the plane of flotation in Sailing Trim.

6.11 Displacement (DSPM & DSPS).

DSPM and DSPS are the weight of the yacht in Measurement Trim and Sailing Trim respectively.

6.12 Wetted Surface (WSS).

WSS is the area of the immersed hull surface in upright Sailing Trim.

6.13 Maximum Draft Including Keel (DHK).

The maximum draft of the hull including fixed keel (DHK) shall be the vertical distance from the Sailing Trim plane of flotation to the lowest point of the hull or fixed keel, whichever is deeper.

6.14 Maximum Draft Adjusted for Centerboard (DHKA).

DHKA is the maximum draft of the hull including fixed keel adjusted for the centerboard and is the draft used for rating purposes.

PART VII – PROPELLER

7.01 General Requirements.

The hydrodynamic drag of the propeller installation shall be taken into account by the Velocity Prediction Program and will be determined from the Propeller Installation Projected Area (PIPA) only if the propeller is at all times ready for use and shall not be retracted, housed, or shielded except by a conventional strut or aperture nor in such a position as to be clear of the water under normal sailing conditions.

7.02 Propeller Types.

7.02.1 Folding Propeller. To qualify for measurement a "folding" propeller shall be a standard model in series production, unaltered, having a minimum of two blades that fold together pivoting on an axis at right angles to the shaft line when not being used for propulsion.

7.02.2 Feathering Propeller. To qualify for measurement a "feathering" propeller shall be a standard model in series production, unaltered, having a minimum of two blades that pivot so as to substantially increase pitch when not being used for propulsion.

7.02.3 Solid Propeller. To qualify as "solid" a propeller shall be a standard model in series production, unaltered, having a minimum of two fixed blades of normal elliptical shape and a maximum width of not less than .25 times the propeller diameter measured across the driving face of the blade on a chord at right angles to the radius of the blade. Pitch shall not be greater than the propeller diameter. Hub and blade area projected into a plane at right angles to the shaft line shall not be less than .2 times the propeller diameter squared. If any of these conditions are not fulfilled the propeller is to be measured as a folding propeller except that if the projected area requirement is confirmed by template and the pitch requirement is confirmed by inspection, all other conditions shall be deemed to have been fulfilled.

7.03 Installation Types.

The propeller installation shall be classified according to the following rules:

7.03.1 In Aperture. To qualify as an "in aperture" installation, the propeller must be solid or three-bladed and entirely surrounded (in the vertical plane of the shaft line) by the keel, skeg, and/or rudder.

7.03.2 Strut Drive. To qualify as "strut drive" the drive train shall be enclosed in a strut and the unit incorporating drive train and strut shall be of a standard model in series production. The surface and shape of the unit may be faired (e.g., with fillers) provided that its function is in no way impaired and none of the dimensions required for measurement of the unit are reduced relative to those as manufactured.

7.03.3 Out of Aperture. All other propeller installations qualify as "out of aperture".

PART VIII – STABILITY AND PITCH GYRADIUS

8.01 Inclining Tests.

Inclining tests shall be made to determine the righting moment of the yacht. Except for inclining apparatus including spinnaker pole(s) as specified below the yacht shall be in measurement trim as detailed in 5.02.2. In the case of a yacht fitted with a centerboard or drop keel which is not locked to prevent movement for measurement and racing, the inclining tests will be carried out with the centerboard or drop keel fully raised. The yacht shall be inclined as detailed below:

8.01.1 A manometer, to the specification circulated to rating authorities, shall be positioned athwart the yacht where it can be read by the measurer, who shall be stationed off the yacht.

8.01.2 Two poles shall simultaneously be positioned port and starboard at the MB station and suspended outboard to provide arms for supporting inclining weights. The poles shall be arranged normal to the yacht's centerline and as nearly horizontal as is possible but allowing sufficient clearance to prevent the weights touching the water. The poles shall be approximately SPL in length and the yacht's pole or poles shall normally be used when available. If a yacht's pole is not used it shall not be on board.

8.01.3 A set of weights shall be prepared (see 8.05). The weights shall be recorded in pounds when the yacht is measured in feet and in kilograms when the yacht is measured in meters. The weights shall be measured and recorded to a level of precision not less than 0.1 of a pound or 0.2 of a kilogram. If water containers are used as weights the scales used for measurement shall be regularly tested to ensure that they are accurate.

8.01.4 When the poles are rigged and all the weights suspended on the starboard side the datum on the manometer shall be marked. In the case of an electronic inclinometer with continuous sampling, a record shall be recorded and the average taken.

8.01.5 The weight shall be transferred to the port side, the measurer recording the weight transferred and the manometer read.

8.01.6 All the weights shall be suspended on the starboard side once again and the datum on the manometer verified following the procedures in 8.01.4.

INCLINING MEASUREMENTS

8.02 Pendulum Length (PL).

Pendulum Length Measured (**PLM**) shall be the length of the manometer from the center line of the fluid reservoir to the centerline of the gauge cylinder; it shall be recorded in millimetres to one place of decimals and shall not be less than 2000.0mm. Gauge surface area (**GSA**) shall be the surface area of the manometer gauge. Reservoir surface area (**RSA**) shall be the surface area of the fluid reservoir. PLM, GSA and RSA shall be common to all readings. PL shall be obtained from the formula:

$$PL = PLM / (1 + GSA / RSA)$$

Note: Where an ORR approved electronic inclinometer is used instead of a manometer, PLM is conventionally recorded as 9000; GSA and RSA as 1.0.

8.03 Weight Distance (WD)

WD shall be the horizontal distance from the point of attachment of the starboard weight to the point of attachment of the port weight. It shall be measured with the weights distributed equally on the two pole ends. The weights shall be attached so that the weight distance is constant for all tests. The weight distance shall be of the order of maximum beam (MB)+2.0*SPL.

8.04 Pendulum Deflections (PD)

PD shall be the deflection on the manometer gauge after each weight of the set has been moved, from the datum established in 8.01.4 above. They shall be recorded in millimetres and shall be within the limits given in 8.05 below.

8.05 Weights (W)

W shall be the total weight suspended from the port pole for each reading of the manometer. The weight shall be of suitable magnitude to ensure that the largest PD is within +/- 0.01*PL of 0.105*PL for yachts with LOA > 41.0 ft and +/- 0.01*PL of 0.125*PL for yachts with LOA <= 41.0 ft.

RIGHTING MOMENT -- MEASUREMENT TRIM

8.06 Inclining Slope (SLOPE)

The slope of the straight line through the inclining weight vs. pendulum deflection is determined.

8.07 Righting Moment (RM).

$$RM=WD*PL*0.0175/SLOPE$$

8.08 Righting Moment Corrected (RMC).

8.08.1 For yachts with fixed keels or centerboards locked to prevent any movement: $RMC=RM$

8.08.2 For movable boards or drop keels, RMC is adjusted for the movement of the board/keel.

RIGHTING MOMENT AND WEIGHTS -- SAILING TRIM

8.09 Righting Moment per Degree in Sailing Trim at 2 degrees Heel (RM2).

RM2 shall be calculated from the displacement and vertical center of gravity in Measurement Trim by the addition of weight for the mainsail (MSW), crew, gear and other sails at their established centers of gravity.

8.10 Righting Moments by Heel Angle (RM2, RM20, RM25, RM40, RM60 and RM90).

These are the Sailing Trim righting moments at 2, 20, 25, 40, 60 and 90 degrees of heel (with all crew on the yacht's centerline) divided by the heel angle in degrees. The VPP uses these to establish the righting moment vs. heel angle curve for the yacht. This stability curve is augmented by moving Crew Weight to the weather rail when appropriate, by dynamic stability effects, and by moveable ballast.

8.11 Crew Weight (CW), Base Crew Weight (BCW).

A maximum crew weight is calculated for each yacht. The owner may, by "owner declaration" (see 8.12), adjust his yacht's maximum allowed crew weight up or down within calculated limits. The VPP takes this crew weight into account. Where no declaration of crew weight has been made, $1.2 * \text{Base Crew Weight (BCW)}$ will be used in the VPP and will be the maximum allowable for racing. BCW is determined by the formula:

$$BCW(\text{lb.}) = \frac{DSPM}{2240} / (.01 * LSM0)^3 / 254)^{.375} * (RM / (DSPM * MB) / .00571)^{.4} * LSM0^{1.55} * 7.6$$

In the above formula, DSPM is displacement in Measurement Trim and MB is the Maximum Beam taken from the hull offsets. RM is the righting moment per degree in standard water in measurement trim with the VCG effect of inclining weights removed. LSM0 is an effective sailing length in Measurement Trim.

8.12 Declared Crew Weight (DCW).

Declared Crew Weight (DCW) shall not be taken as less than the greater of 555.0 lb. or 0.65 times the calculated default for the yacht. Nor shall DCW be taken as greater than 1.2 times the calculated default. Yachts with DCW greater than default do not get credit for the extra crew being above the yacht's sailing trim VCG. These yachts will have sailing trim calculated with default crew weight, but the full DCW will be used in calculations that move crew onto the rail in optimizing performance to sailing conditions.

PITCH GYRADIUS

8.13 Elements of Pitch Gyadius.

The following elements of the pitch gyadius calculation shall be determined by examination of the yacht and recorded on her certificate. Where deemed appropriate, a declaration from the owner may be substituted for examination of one or more elements, but all elements are subject to examination at any time in cases of doubt.

8.13.1 Hull and Deck Construction. Owners are reminded of their obligations under ORR 3.02.4. Hull and deck construction shall be classified as one of the types below. Note that limited amounts of high strength carbon edge capping of bona fide hull structural frames, girders and stringers, and as localized reinforcement on bulkhead faces in way of chainplate attachments, will not affect the hull construction category provided it is used below decks between 0.3LOA and 0.7LOA aft of the stem.

SOLID: Non-cored, solid E-glass, metal or wood hull and deck, but including also E-glass decks with core material. Where the construction is of wood, the minimum density of any layer shall not be less than 300 kilograms per cubic meter.

CORED: Hull skin of E-glass (see above) or wood, but incorporating a core material of less density than the skin.

LIGHT: All other construction types, but excluding the incorporation of any carbon fiber (see below).

CARBON: Where carbon fiber has been incorporated anywhere in the construction of the hull and/or deck.

HCMB: In addition to recording the appropriate construction type as above, where a honeycomb core has been incorporated in hull or deck construction, this shall also be recorded.

8.13.2 Rudder Construction. Rudder construction shall be classified as one of the following:

STANDARD: Neither rudder nor rudder post contain any carbon fiber.

CARBON: Rudder and/or rudder post contain carbon fiber in any amount.

8.13.3 Forward Accommodation. Where the bow forward of the mast is fully fitted out as a separate sleeping or living space built of solid construction, including bunks (pipe berths do not qualify), personal gear stowage, etc., the yacht shall be classified as having Forward Accommodation which shall be recorded on the Certificate.

8.13.4 Number of Spreader Sets. The number of sets of mainmast spreaders shall be recorded on the Certificate.

8.13.5 Jumper Struts. Where the mainmast incorporates jumper struts, this shall be recorded on the Certificate.

8.13.6 Number of Runners (Inner Backstays) and Adjustable Inner Forestays; see 9.12.4.

8.14 Assessment of Pitch Gyradius.

The VPP assesses the added resistance of the hull resulting from sailing in wind-driven waves using a routine which estimates a base pitch gyradius. The pitch gyradius is an indicator of how spread the weights of a boat are. A small gyradius indicates that the weights are relatively concentrated. In general, the higher the gyradius is, the greater the added resistance. Adjustments are made to the base gyradius according to the following recorded characteristics of the yacht:

8.14.1 If Mast Weight (MWT) and Mast Center of Gravity (MCG) have been recorded, the gyradius contribution of the mast is assessed as compared to that of a hypothetical base aluminum mast and a corresponding mathematical gyradius adjustment is made.

8.14.2 For a yacht measured afloat with a carbon mast, where MWT and MCG are not recorded, the base gyradius shall be adjusted by a default mast gyradius increment.

8.14.3 If MWT and MCG are not recorded, the gyradius is increased in accordance with the number of spreader sets, jumpers struts, adjustable inner forestays and running backstays.

8.14.4 Further gyradius adjustments are made for:

- a) Mizzen mast,
- b) Hull construction: SOLID, CORED, LIGHT, CARBON, HONEYCOMB,
- c) Age Date,
- d) Forward Accommodation,
- e) Carbon fiber rudder construction.

PART IX – RIG

9.01 Rig Restrictions

- 9.01.1** Yachts shall have substantial, bona fide mainsails. No yacht shall be rated under ORR if P+BAS is less than the greater of $.96*IG$ or $.96*ISP$.
- 9.01.2** Rotating and/or pivoting masts are prohibited from ORR.
- 9.01.3** A yacht must have a bona-fide forestay. That forestay may be adjustable, if so it will be rated as such. **The forestay shall remain attached at all times while racing.**
- 9.01.4** The following adjustments to rigging are permissible unless a specific rig element has been declared not adjustable for rating purposes:
- a) Forestays.
 - b) Main Backstays.
 - c) Runner Backstays.
 - d) Mizzen Backstays.
 - e) Checkstays.
- 9.01.5** No yacht shall be rated under ORR if any spar is built wholly or in part of any material other than wood, aluminum alloys, steel alloys or fiberglass reinforced plastic, except as provided in a) and b)
- a) the restrictions of this section do not apply to booms and spinnaker poles.
 - b) if the mast is constructed substantially of carbon in section throughout its entire length. In such case carbon fiber reinforced plastic is permitted for masts as well as integral mouldings, spreaders, and jumpers.
- 9.01.6** Permanently bent spars are not permitted. A spar that will straighten when stresses imposed by the rigging are removed does not constitute a permanently bent spar.
- 9.01.7 Movement of Mast at Deck Step.** Altering the location of the mast at the step or deck while racing is not permitted.
- 9.01.8 Adjustment of Rigging.** Adjustment of rigging while racing is not permitted except as specifically set forth below. Otherwise all means of adjustment must be positively locked and/or bound up to prevent accidental adjustment while racing. The following adjustment is permitted while racing except where an element of rigging has been declared not adjustable for rating purposes:
- a) For purposes of safety, i.e. an exceptional adjustment of a stay to cure a fault.
 - b) Where a mast is rigged with all spreaders clearly swept aft (spreader angle greater than 10 degrees), the forestay of that mast may be adjusted and must be declared as such for rating purposes.
 - c) Inner forestays attached to the foremost mast between $0.225*IG$ and $0.75*IG$ above the sheerline.
 - d) Main backstays. If adjustable, main backstays must be declared as such.
 - e) Runner backstays.
 - f) Mizzen backstays.

RIG MEASUREMENT

9.02 Sail and Rig Measurement.

All spars and standing rigging, adjustable or fixed, must be available to the Measurer for measuring or checking marked dimensions and declarations made as to the use of these while racing (see also 3.02.3).

9.03 Painted Measurement Bands.

Measurements may be taken to locations defined by painted bands, of black or other contrasting color, only when these bands are in place at the time of measurement. Where measurements are taken to such bands, movement of the bands or a failure to display them while racing shall invalidate the rating certificate.

FORETRIANGLE

9.04. Base of Foretriangle (J).

J shall be the actual foretriangle base measured horizontally from the foreside of the mast at its lowest point above the deck or coachroof to the center line of the foremost stay on which jibs are set (the center line of the luff if the foremost jib is to be set flying), extended if necessary, to intersect the level of the sheer line, or to a bowsprit if used. Where there is the capacity for the mast to be moved at the deck, J shall be measured with the mast at the aftermost limit of adjustment unless a 1 in. (25mm) contrasting band is provided. In this case J shall be measured to the aft edge of the band and the forward face of the mast may not move aft of this point.

9.04.1 Stem to Forward End of J (SFJ)

SFJ shall be the horizontal distance from the forward end of J to the forward end of LOA (negative if a bowsprit is used).

9.05. Spinnaker Pole and Spinnaker Tack Point (SPL & TPS).

9.05.1 The yacht's spinnaker configuration shall be declared by the owner and recorded as one of three permitted types:

- a) Symmetric: all spinnakers are symmetric, spinnaker pole allowed.
- b) Centerline Asymmetric: no spinnaker pole allowed aboard the yacht while racing, any spinnaker to be tacked only on the centerline of the yacht.
- c) Asymmetric: asymmetric and symmetric spinnakers allowed, spinnaker poles allowed.

9.05.2 Spinnaker Pole Length (SPL). SPL shall be the length of the spinnaker pole when forced outboard in its fitting on the mast and set in a horizontal position athwartships, measured from the center line of the yacht to the extreme outboard end of the pole and any fittings used when a spinnaker is set.

9.05.3 Tack Point of Spinnaker (TPS). TPS shall be the horizontal distance from the foreside of the mast at its lowest point above the deck or coachroof to the point of attachment at deck level of the foremost tacking point of an asymmetric spinnaker or to the extreme forward end of any bowsprit in its maximum extended position.

MAIN MAST AND BOOM

9.06 Mast Measurements.

Measurements shall be taken parallel to the axis of the spar with the spar straight.

9.06.1 Height of Genoa Halyard (IG). IG shall be the genoa height measured from the point of attachment of the forestay to the mast structure, or the intersection of the center line of the forestay with the foreside of the mast where the point of attachment is internal, to the level of the deck as defined in 9.08.

9.06.2 Height of Spinnaker Halyard (ISP). ISP shall be the height of the uppermost spinnaker halyard. It shall be measured from the underside of the spinnaker halyard, when drawn horizontally forward from the mast, to the level of the sheer line abreast the mast as defined in 9.08.

9.06.3 Forestay Outrigger (GO). GO shall be the horizontal distance from the upper point of measurement used to determine IG to the after side of the mast or vertical projection of the after side of the mast.

9.06.4 Mast Width (MW). MW shall be the minimum fore and aft width of the mast to be found at any point below the top of IG and above the lower spreader.

9.06.5 Maximum Transverse Dimension of Mainmast (MDT1). MDT1 shall be the maximum thickness of the mast in the athwartships direction occurring above $0.5 \cdot P$.

9.06.6 Maximum Longitudinal Dimension of Mainmast (MDL1). MDL1 shall be the maximum thickness of the mast in the fore and aft direction occurring above $0.5 \cdot P$.

9.06.7 Taper Length (TL). TL shall be the distance from the highest point at which MDT1 or MDL1 occurs, whichever is lower, to the upper measurement point for P.

9.06.8 Upper Transverse Dimension of Mainmast (MDT2). MDT2 shall be the minimum thickness of the mast in the athwartships direction below the upper measurement point for P.

9.06.9 Upper Longitudinal Dimension of Mainmast (MDL2). MDL2 shall be the minimum thickness of the mast in the fore and aft direction below the upper measurement point for P.

If the thickness of a mast (constructed of materials other than wood) in the athwartships direction is less than MDT1, or in the fore and aft direction is less than MDL1, at any point below the highest points at which they occur, the smallest athwartship value found shall be substituted for MDT1 and the smallest fore and aft value found shall be substituted for MDL1, except that any bona fide luff groove shall always be included. Any such substitution shall not affect the definition of TL. Excluding a luff groove device, no hollows in section are permitted. Any addition of material to the base mast section shall consist of

the same primary structural material as the mast itself. The MDL measurements shall include any bona fide luff groove or track attached directly to or integral with the mast. Any secondary luff groove device otherwise attached shall not be included and the relevant boom and mainsail measurements shall be increased by the longitudinal dimensions of the device as determined by the Measurer.

9.07 Mainsail Hoist (P).

P shall be the measured length of the hoist of a jib headed mainsail. It is the distance along the afterside of the mainmast from the highest level to which the head of the sail, or any part of a headboard carriage abaft the track or mast groove, may be set to the lowest position of the tack. The highest point shall be taken as the top of the highest sheave used for the main halyard, or to the lower edge of a one-inch measurement band. The lowest position of the tack shall normally be the fair extension of the top of the boom or any external track or groove.

9.07.1 If a sliding gooseneck is used, measurement is to be made with the boom at the extreme bottom of the slide unless the lowest sailing position of the foot of the sail (boom or boom track) is marked by the upper edge of a one-inch measurement band around the mast. The top of the boom (or track) shall not be carried below this point when the mainsail is set, except when actually putting in or shaking out a reef in the mainsail.

9.07.2 In the event that the tack of the sail is carried below the boom, its lowest position shall be marked by the upper edge of a one-inch measurement band around the mast from which the low point of P shall be measured.

9.08 Height of Deck.

The height of deck used as a datum for sail area measurements shall be the sheer line abreast the mast.

9.09 Boom above Sheerline (BAS).

BAS shall be the distance between the low point used in the determination of P and the level of the deck as defined in 9.08.

9.10 Foot of Mainsail (E & BAL).

9.10.1 Foot of Mainsail (E). E shall be the length measured along the boom from the aft side of the mast including any external track or groove, or its fair extension parallel to the axis of the mast, to the aftermost position to which the sail is permitted to extend. Where this latter point is inside of the boom end, it shall be located by the inner edge of a one inch measurement band around the boom.

Any part of the mast which extends abaft the aft side of the track or mast groove shall be ignored in determining E.

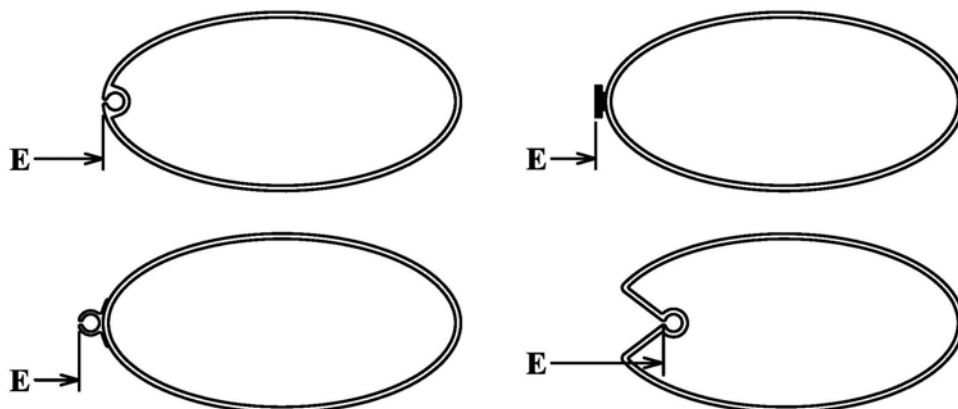

9.10.2 Sheeting Limit (BAL). BAL shall be the distance from the outer measurement point of E to a contrasting measurement band denoting the limit on the boom beyond which no lead for the sheeting of headsails shall be attached. In the absence of such a band BAL shall be measured to the boom end. BAL shall not exceed 0.152 m (0.50 ft.).

9.11 Boom Diameter (BD).

BD shall be the maximum dimension of the main boom measured in section inclusive of any structure used to stiffen the boom. A boom with a BD in excess of $0.05 \cdot E$ is not permitted.

9.12 Rigging Plan.

Stays which are adjustable fore and aft while racing shall be declared by the owner, confirmed by the Measurer and recorded as follows:

9.12.1 Adjustable Forestay. When the forestay itself is adjustable this shall be recorded as "adjustable forestay".

9.12.2 Adjustable Backstay. When the uppermost backstay is adjustable this shall be recorded as "backstay adjustable".

9.12.3 Adjustable Forestay and Backstay. There is no restriction on having simultaneously an adjustable forestay and an adjustable backstay on a boat equipped with swept spreaders (see 9.01.8b). There is an appropriate rating adjustment in the VPP.

9.12.4 Running Backstays. Where there are one or more pairs of backstays below the uppermost backstay (inner backstays, runners, checkstays, etc.), these shall be recorded as "runners". The number of pairs, based on the attachment points on the mast, shall also be recorded (see also 8.13.6). A secondary runner tension adjuster, leading to the mast approximately perpendicular to the runner itself, shall not be counted.

9.13 Chainplate Width (CPW).

CPW shall be the distance between the centers of the bearing points of the chainplates for the upper shrouds of the mainmast.

9.14 Rig Weight and Center of Gravity (MWT, MCG & WB).

This is required for carbon masts; optional for other masts.

- 9.14.1** The main mast, together with its standing rigging, shall be weighed and the weight found recorded as **MWT**.
- 9.14.2** The vertical center of gravity shall be determined relative to the lower measurement point of P and recorded as **MCG**.
- 9.14.3** As appropriate to the size of the mast, the values for MWT and MCG may be found either by measurement at the single point of the center of gravity of the mast and rigging or by measurement of tip and butt weights separately, followed by calculation of the values to be recorded.
- 9.14.4** The weight of the boom shall be separately recorded as **WB**.
- 9.14.5** All measurements above shall be taken with the components dry and the spars fitted only with components with which the yacht will actually race as specified below.
- 9.14.6** The mast shall be completely rigged with standing rigging, running backstays, spreaders, jumpers, lights, antennae, wiring, luff groove device and all other permanently attached fittings, including those turnbuckles which are not permitted to be adjusted while racing.
- 9.14.7** Excluded for measurement shall be running rigging, checkstays, rigging adjusters of any type (hydraulic or otherwise) and any associated blocks and tackle, boom vang and reefing tackle. Halyard messengers of not more than 4mm diameter and weighing not more than 15 grams per meter and only sufficient for convenient re-leading may be used to replace internal portions of running rigging.
- 9.14.8** All wiring, messengers and standing rigging shall be in their proper attached positions, and any slack stretched down and secured along the length of the mast with light material, such as lanyards or tape, with any tails hanging free at the butt.
- 9.14.9** Headboard, luff slides, spinnaker pole cars and any other adjustable devices shall be at their lowest limit of travel.

MIZZEN MAST AND BOOM

9.15 Height of Mizzen Mast (IY).

IY is the height measured along the foreside of the mizzen mast from the deck as defined in 9.08 to the higher of:

- 9.15.1** The center of the highest eyebolt or eye used for a mizzen staysail;
or
- 9.15.2** The intersection of the foreside of the mast with the highest strop used for the halyard of a mizzen staysail.

9.16 Mizzen Mast Diameters and Taper Length (MDT1Y, MDL1Y, MDT2Y, MDL2Y & TLY).

Mizzen diameters and taper measurements are as for main masts (ref. 9.06.5 through 9.06.9).

9.17 Mizzen Hoist (PY).

PY is the measured length of the hoist of a jib headed mizzen sail. The method by which this is measured shall follow that used for the hoist of the mainsail (see 9.07).

9.18 Boom above Sheerline (BASY).

BASY shall be the distance between the low point used in the determination of PY, and the level of the deck as defined in 9.08.

9.19 Foot of Mizzen.

9.19.1 Foot of Mizzen (EY). EY is the measured length along the boom from the aft side of the mizzen mast including any external track or groove, or its fair extension parallel to the axis of the mast, to the aftermost position to which the sail is permitted to extend. The method by which this is measured shall follow that used for the foot of the mainsail (see 9.10).

9.19.2 Sheeting Limits (BALY). BALY is the distance from the outer measurement point of EY to any bale on the mizzen boom provided for the lead of any mizzen staysail sheet, limited as for BAL.

9.20 Mizzen Boom Diameter (BDY).

BDY shall be the maximum dimension of the mizzen boom measured in section inclusive of any structure used to stiffen the boom.

9.21 Distance between Masts (EB).

EB is the distance at deck level between the after side of the mainmast to the foreside of the mizzen mast.

PART X -- SAILS

All sails must be available to the Measurer for measuring or checking marked dimensions and declarations made as to the use of these while racing (see also 3.02.3 & 9.01).

SAIL RESTRICTIONS

10.01 Construction.

10.01.1 The term "sail" shall be taken to include the headboard, tabling, bolt and foot rope or tapes. It shall not include cringles which are wholly outside the sail.

10.01.2 Openings in the sail, in addition to the normal cringles and reefing eyelets, are permitted provided that the sail is flat in the vicinity of the openings.

10.02 Sail Inventory

10.02.1 A yacht while racing shall not carry on board more sails of each type than the numbers below:

Large jibs	5
Small jibs	4
Light staysails	1
Spinnakers	5
Mainsails	1
Storm Trysails	1
Storm Jibs	1
Heavy -Weather Jibs	1
Mizzens	1
Mizzen Staysails	3

- Large jibs are those having an LPG greater than 1.1*J.
- Small jibs are those having an LPG less than or equal to 1.1*J. Sails in this category, except inner forestaysails, must be set on stays permanently attached to the mast and tacked on the centerline of the yacht. Inner forestaysails must also be tacked on the centerline of the yacht, but need not be set on a stay.
- Where the largest jib for which a yacht is rated is a Small Jib, the total number of jibs allowed shall be the Small Jib maximum plus two.
- Light staysails are those having an LPG less than or equal to 1.1*J which shall only be set flying.
- The specifications of storm and heavy weather sails are those of the Offshore Special Regulations Governing Offshore Racing, section 4.26.4.

10.02.2 For long distance races the race organizer may modify these limitations to permit carrying additional sails of the kinds and numbers appropriate to the character of the race.

10.03 Trimming of Sails.

All sails must be set and trimmed in a manner consistent with the way they are measured. A sail shall not be constructed in such a manner that any portion may be completely detached.

10.04 Double Luffed Sails.

Double luffed sails (those with thick or wrap-around luffs, not spinnakers) are not permitted.

10.05 Restrictions on Setting and Sheeting of Jibs

- a) When a jib is set under a spinnaker or inside another jib, it shall not be tacked in such a position that, if the sail were trimmed flat along a parallel to the center line of the yacht, its clew would fall abaft the LP line (see b below).
- b) The LP line is defined as a line abaft and parallel to the foremost headstay and separated from it by the dimension of LP printed on the Rating Certificate. The foremost headstay is defined as the line joining the upper measurement point of IG and the forward measurement point of J.
- c) If a jib is set under or abaft another headsail, it shall not be so tacked that, if trimmed along a parallel to the center line of the yacht, more than 50 per cent of its area would fall abaft the foreside of the mast.
- d) No tack pennant greater than 0.762m (2.5 ft) may be used on a jib (except the storm jib) when set flying.
- e) No jib shall be so tacked that the forward end of any batten is aft of the center line of the mast.
- f) Jibs may be sheeted to any part of the deck or rail, but to no fixed point higher than $0.05 \cdot B$ above the deck or coachroof, or to the main boom, within the measurement limits (see 9.10.2) or to the spinnaker pole when the pole is set on the opposite side from the main boom but may not be sheeted to any other spar or outrigger.
- g) No jib may be set in conjunction with any other headsail so as by any means to simulate a double clewed or double luffed jib. (For example, except when changing sails, no two jibs may be carried simultaneously in a luff groove device and sheeted on the same side of the yacht.)

10.06 Restrictions on Setting and Sheeting of Spinnakers

- a) The outboard end of the spinnaker pole shall be used only on the windward side of the yacht (i.e. that opposite to the main boom). A spinnaker pole shall only be used with its inboard end attached to the mast (foremast if there is more than one mast).
- b) A bona fide jib (see 10.16) for which the yacht has been measured may be set and sheeted as a spinnaker where either of the following conditions apply:
 - 1. In heavy weather when no other sail is set in the foretriangle and the apparent wind is abaft the beam, or
 - 2. When all spinnakers aboard have been damaged beyond repair during the race.A jib so set may have either its tack or clew to the spinnaker pole.
- c) Spinnakers shall be sheeted from only one point on the sail.

- d) A spinnaker may be sheeted to any part of the rail or deck or to the main boom, within the measurement limits (see 9.10.2), but to no other spar or outrigger.
- e) Struts, spools or similar devices used solely for the purpose of keeping the spinnaker guy away from the windward main or foremast shrouds are permitted but are not to be used for any other purpose.
- f) Where the spinnaker configuration is classified as Centerline Asymmetric (i.e., no pole allowed on board – see 9.05.1b), the spinnaker shall be tacked on the centerline of the yacht and sheeted on the same side as the boom

10.07 Restrictions on Setting and Sheeting of Mainsails

- a) Mainsails shall be either fully secured at the foot or fully loose footed and shall remain so while racing. A mainsail secured at the foot shall be provided with a bolt rope, track or tunnel slides, or similar boom attachment that prevents the foot from lifting away from the boom. A loose-footed mainsail shall be sheeted only from a single clew.
- b) Spare mainsails are not permitted to be carried on board.
- c) Storm trysails, as distinguished from loose-footed mainsails, must be materially smaller than a normal close-reefed mainsail and of a strength consistent with their purpose viz. use in extremely severe weather (see ORC Special Regulations 4.24(b)). Aromatic polyamides and other high modulus fibers shall not be used in the storm trysail.
- d) Headboard carriages are permitted only if the sail is set and trimmed in a manner consistent with the way HB was measured (see 10.30).

10.08 Restrictions on Setting and Sheeting of Mizzen Staysails on Yawl or Ketch

- a) Mizzen staysails may be sheeted to the rail or hull, and to the mizzen boom within the measurement limits (whether or not the mizzen is set) but they may not be sheeted to any other spar or outrigger.
- b) Mizzen staysails must be three-cornered (head, tack and clew). The tack or tack pennant must be secured abaft the point of intersection of the afterside of the mainmast with the main deck and also must be secured directly to and no higher than the rail cap, deck or cabin top (includes dog house top).
- c) Not more than one mizzen staysail may be set at the same time.
- d) No mizzen staysail may be carried on a yawl or ketch whose mizzen is set on a permanent backstay in lieu of a mizzen mast.

SAIL MEASUREMENTS

10.09 Tension and Wrinkles in Sails

When measuring sails it is required that sufficient tension be applied between measurement points as to remove all wrinkles across the line of measurement and must include the fabric length between measurement points.

10.10 Measurement Points at Corners of Sails

Measurement points at the corner of a sail shall be the intersection of the adjacent sides projected except in the case of the head of a jib which shall be determined in accordance with the diagrams below. For jibs other than storm jibs, the head measurement point is the highest point of the sail. In the case of a storm jib the head measurement point is the lower of the highest point of the sail or the intersection of the adjacent sides projected. All other measurement points shall be at the extreme outside of rope, wire or fabric of the sail's edge.

Measurement points at the heads of Jibs.

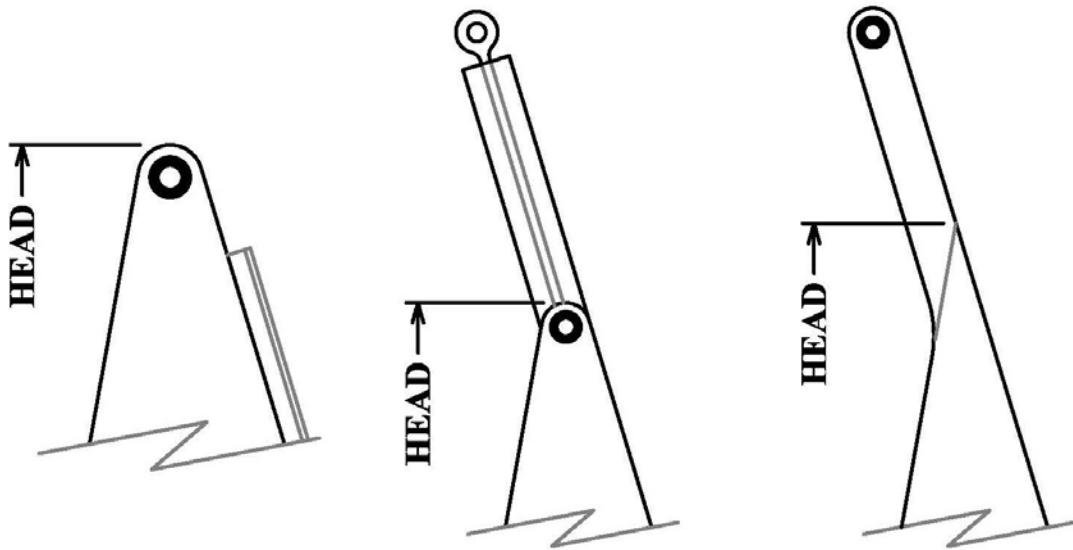

10.11 Definition of Headsails.

The word headsail is defined as a sail set in the foretriangle. It can be either a spinnaker or a jib.

MEASUREMENT OF JIBS

10.12 Longest Perpendicular of Jibs (LPG).

10.12.1 Jibs shall be measured on the perpendicular from the luff (outside edge of the sail and/or luff rope) to clew (intersection of the lines of the foot and leech). A wrap-around jib shall be measured on the perpendicular from the line of junction of the wrap-around parts to the clew.

10.12.2 LPG shown on the rating certificate shall be the value for the largest area jib carried on the yacht.

10.13 Jib Girths and Jib Roach (JR).

- 10.13.1** From any specified point on the leech of a jib, the mid-girth is defined as the distance from that point to the nearest point on the luff of the jib.
- 10.13.2** JMGL, JMGM, JMGU shall be the mid-girths, as defined in 813.1 above, from respectively 25%, 50%, and 75% of the leech length from the clew.
- 10.13.3** JLE shall be the straight line distance from the jib head to jib clew.
- 10.13.4** JLU, JLE, LPG, JMGL, JMGM, and JMGU shall be measured for each jib and recorded on that jib's sail certificate.
- 10.13.5** Jib Roach (**JR**) is defined as the maximum excess of the three girths JMGL, JMGM, JMGU over the base girths of respectively 75%, 50%, 25% of LPG. 75% of JR shall be multiplied by JLE for the purpose of calculating the roach area.
- 10.13.6** For no mid girths shall the girth excess, as defined in 10.32, exceed 12% of its respective base girth.
- 10.13.7** The JR and JLE for the largest area jib shall be shown on the certificate.

10.14 Forestay Perpendicular (FSP).

FSP shall be the larger of either:

1. Twice the maximum dimension, measured at right angles to the longitudinal axis, of a luff groove device;
- or
2. The largest dimension of the doubled portion of a wrap-around jib measured at right angles to the luff line when opened out.

10.15 Longest Luff of Jibs (JL).

The length of the luff shall normally be the distance between the lowest part of the sail on the luff rope at the tack and the highest point of the sail on the luff rope at the head. JL shall be recorded as the largest such dimension found on the jibs carried on the yacht.

MEASUREMENT LIMITATIONS ON JIBS

10.16 All jibs are subject to the following limitations:

- 10.16.1** The distance, measured on the surface of the sail, between the midpoint of the foot and the midpoint of the luff shall not exceed 0.55 of the length of the leech.
- 10.16.2** Except in non-overlapping self-tacking jibs no clew boards may be used in jibs.
- 10.16.3** No headboards may be used in jibs.

- 10.16.4** Except that battens are not permitted in jibs of LPG greater than $1.1*J$, battens may be used in jibs only if the number of battens is limited to four, which must be arranged with approximately equal spacing between head and clew (see also 10.05 (e)).
- 10.16.5** A yacht may use a luff groove device provided that such luff groove device is of constant section throughout its length and is either essentially circular in section or is free to rotate without restraint. Any permitted device on the forestay other than hanks shall be measured for FSP (see 10.14).
- 10.16.6** Jibs may be sheeted from only one point on the sail except in the process of reefing the sail. (Thus quadrilateral or similar sails or sails in which the sailcloth does not extend to the cringle at each corner are excluded.)
- 10.16.7** Aromatic polyamides, carbon fibers and other high modulus fibers shall not be used in the storm jib.

DEFINITION OF SPINNAKERS

10.17 Symmetric Spinnakers.

To be classified as a symmetric spinnaker a sail must meet the following criteria:

- 10.17.1** The luff and leech (see 10.21) must be of equal length.
- 10.17.2** The sail must be symmetric, in shape, material and cut, about a line joining the head to the center of the foot.

10.18 Asymmetric Spinnakers.

To be classified as an asymmetric spinnaker a sail must meet the following criteria:

- 10.18.1** The luff shall be at least 5 percent longer than the leech (see 10.21).
- 10.18.2** The mid girth (see 10.23) shall not be less than 75 percent of the foot length (see 10.22).

MEASUREMENT OF SPINNAKERS

10.19 Spinnaker Headboard (HBS).

HBS shall be the maximum width of a spinnaker headboard, which shall not exceed $0.05*J$.

10.20 Spinnaker Maximum Width (SMW).

SMW for a symmetric spinnaker shall be the spinnaker maximum width, whether at the foot or across the body of the sail between points on the luff and leech equidistant from the head.

10.21 Spinnaker Luff and Leech (SL & ASL).

10.21.1 Symmetric Spinnaker Luff and Leech (SL).

SL shall be the greatest length of a symmetric spinnaker luff and leech measured along the edges of the sail from head to foot.

10.21.2 Asymmetric Spinnaker Luff (ASL).

- a) SLU shall be the length of the longer edge (luff) of an asymmetric spinnaker measured along the edge of the sail from head to tack.
- b) SLE shall be the length of the shorter edge (leech) of an asymmetric spinnaker measured along the edge of the sail from head to clew.
- c) ASL shall be calculated from the following formula:

$$ASL = 0.5 * SLU + 0.5 * SLE$$

For symmetric spinnakers, where stiffening is used to widen the angles at the tack and clew beyond an included angle of 110 degrees the greatest length of any such stiffening along the foot, measured from the clew, shall be added to the luff length to determine SL.

10.22 Spinnaker Foot Length (SF & ASF).

Spinnaker foot length shall be the distance from tack to clew measured in the shortest path on the surface of the sail. For a symmetric spinnaker, the distance shall be recorded as SF. For an asymmetric spinnaker, the distance shall be recorded as ASF.

10.23 Asymmetric Spinnaker Mid Girth Length (AMG).

AMG shall be the distance between the midpoints of luff and leech measured in the shortest path on the surface of the sail.

10.24 Measurements for Spinnaker Area

For calculation of sail area the dimensions of HBS, SMW, AMG, SF, ASF, SL and ASL shall be from the spinnaker with the largest area (see) carried on the yacht, but also see 10.45 for rated minimum SMW, AMG, SF, ASF, SL and ASL.

MEASUREMENT LIMITATIONS ON SPINNAKERS

10.25 All spinnakers are subject to the following limitations:

10.25.1 A sail shall not be measured as a spinnaker unless the mid girth is 75 per cent or more of the foot length.

10.25.2 Battens shall not be used in spinnakers.

10.26.3 Adjustable leech lines are not permitted in symmetric spinnakers.

MEASUREMENT OF MAINSAILS

10.26 Mainsail Head - The head shall be taken as the highest point of the sail projected perpendicular to the luff or its extension.

10.27 Mainsail Clew - The clew shall be taken as the aftermost part of the sail projected to the foot of its extension.

10.28 Mainsail Cross Widths - The cross measurements shall be the distance from the leech measurement points, as defined below, to the nearest point on the fore edge of the sail including their bolt rope. The points on the leech from which the cross measurements are taken shall be determined bridging any hollows in the leech with straight lines.

10.29 Mainsail Mid Point of Leech - The mid-point of the leech shall be determined by folding the head to the clew and the quarter and three-quarter leech points by folding the clew and the head to the mid-point leech. The seven-eighth leech point is determined in a similar fashion.

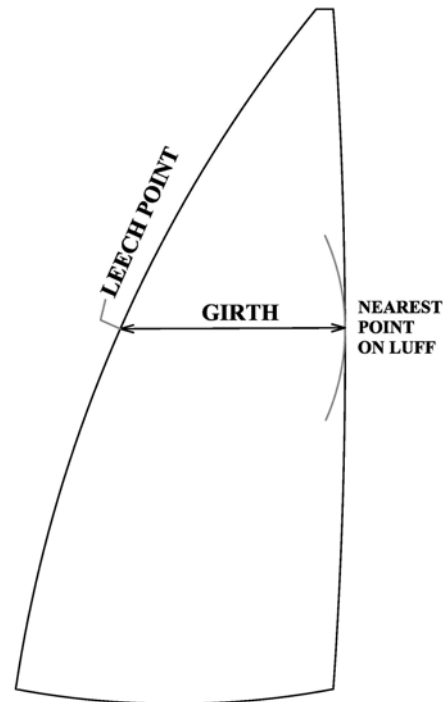

10.30 Mainsail Headboard (HB).

Where the center line of the top batten pocket is not situated above the MGT leech measurement point, HB shall be the maximum fore and aft dimension from the luff of the mainsail, projected if necessary, to the extreme aft edge of the leech measured across the widest part of the headboard. If the widest point of the headboard is in doubt, the highest of the widest points shall be used. If no headboard is fitted, then HB shall be the dimension taken perpendicular to the luff of the mainsail, or its fair projection, to the extreme aft edge of the leech, or its fair projection, across the bearing surface of the head cringle or strop. Any stiffening used to extend the leech beyond a reasonable roach shall be added to HB. HB has as a limit the greater of $0.04 * E$ or 0.152m (0.5 ft).

10.31 Top Batten Upper Limit – Determination of HB

Where the center line of a batten pocket is situated above the MGT leech measurement point, HB shall be measured as diagrammed below and recorded to the nearest cm (metric) or nearest tenth of a foot (imperial) as for sails. A straight line extension of a line from the leech measurement point of MGT through the outer tip of the batten above MGT giving the greatest value for HB shall determine the aft measurement point for HB.

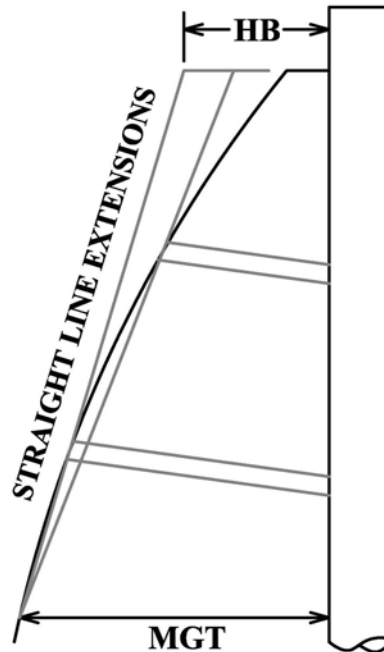

10.32 Mainsail Girths (MGT, MGU, MGM, & MGL).

10.32.1 MGT, MGU, MGM and MGL shall be the length of the girths of the mainsail taken at points 7/8, 3/4, 1/2 and 1/4 of the leech from the clew respectively, measured in accordance with 10.28. The values recorded for MGT, MGU, MGM and MGL shall be the largest to be found on any mainsail used on the yacht.

10.32.2 Standard Mainsail Girths.

- The standard for MGT is $0.22 * E$
- The standard for MGU is $0.38 * E$
- The standard for MGM is $0.65 * E$
- The standard for MGL is $0.89 * E$

In ORR a mainsails is rated on both its actual area and the vertical distribution of that area. These standard girths are nominal values only. Where any girth exceeds its limit, a rating assessment shall be applied.

10.32.3 The rules for mainsail girths and limits apply to mizzens by appropriate substitution.

10.33 Mainsail weight (MSW).

MSW shall be the dry weight of the mainsail not including battens (see also 2.06.1). The value of MSW for any calculation shall be the smallest found on any mainsail used for racing.

10.34 Batten Adjustment

No device other than a normal leech line shall be employed to adjust the curvature of any batten.

MEASUREMENT OF MIZZEN SAILS

Where noted, rules under the Mainsail section apply also to mizzens by substitution of the corresponding mizzen values.

10.35 Mizzen Headboard (HBY).

HBY shall be the maximum fore and aft dimension from the luff, projected if necessary, to the extreme aft edge of the leech measured across the widest part of the headboard. If the widest point of the headboard is in doubt, the highest of the widest points shall be used. By substitution, the HB limit applies to HBY.

10.36 Mizzen Top Batten upper limit.

The center line of the top batten pockets shall not be situated above the MGTY leech measurement point.

10.37 Mizzen Girths (MGTY, MGUY, MGYM & MGLY).

Mizzen girth measurements are as for mainsail girths (reference 10.32).

10.38 Mizzen Batten Adjustment.

No device other than a normal leech line shall be employed to adjust the curvature of any mizzen batten.

MIZZEN STAYSAIL

10.39 Mizzen Staysail Foot (YSF).

Mizzen staysails shall be three-cornered. YSF is the distance measured along the edge of the foot of the mizzen staysail from tack to clew. For measurement purposes, the foot shall be taken as the shortest side. YSF shall be the largest such dimension found on the staysails carried on the yacht.

10.40 Mizzen Staysail Depth (YSD).

YSD is the shortest distance that can be measured across the mizzen staysail from head to foot. For measurement purposes the head shall be taken as the junction of the two longest sides. YSD shall be the largest such dimension found on the staysails carried on the yacht.

10.41 Mizzen Staysail Mid Girth (YSMG).

YSMG is the distance measured on the surface of the sail between the mid points of the two longest sides. YSMG shall be the largest such dimension found on the staysails carried on the yacht.

RATED ELEMENTS OF THE AERODYNAMICS MODEL

Sail and rig dimensions are used by the Velocity Prediction Program to create an aerodynamic model of the sail plan and rig from which it calculates lift and drag factors to determine the heeling and propulsive force of the sails in different wind velocities and points of sailing.

10.42 Sail Plan Rated Areas.

For the purpose of the aerodynamic model, areas are calculated as follows.

10.42.1 Foretriangle: The area of the foretriangle is determined as $IM \cdot J / 2$.

10.42.2 Jib: The area is determined as $(IM^2 + J^2)^{0.5} \cdot (LP) / 2$.

10.42.3 Spinnakers:

- a) Symmetric Spinnaker: For the purpose of the aerodynamic model, the area of a symmetric spinnaker is determined as $SL \cdot (0.5 \cdot SF + 2 \cdot SMW) / 3$.
- b) Asymmetric Spinnaker: For the purpose of the aerodynamic model, the area of an asymmetric spinnaker is determined as $ASL \cdot (0.5 \cdot ASF + 2 \cdot AMG) / 3$.

10.42.4 Main and Mizzen: Mainsail area is determined by trapezoidal integration of P, E, MGT, MGU, MGM, MGL and HB:

$$\text{Area} = (P/4 \cdot (E + MGL)/2) + (P/4 \cdot (MGL + MGM)/2) + (P/4 \cdot (MGM + MGU)/2) + (P/8 \cdot (MGU + MGT)/2) + (P/8 \cdot (MGT + HB)/2)$$

Where the value for any girth has not been recorded, the corresponding girth limit is substituted. The mizzen area is calculated by the method given above for the mainsail, substituting the corresponding mizzen values.

10.42.5 Mizzen Staysail: The area of a mizzen staysail is determined as:

$$\text{Area} = YSD \cdot (2 \cdot YSMG + YSF) / 4.$$

10.43 Foretriangle Height (IM).

$$IM = (IG + IG \cdot (GO - MW) / (J - GO + MW))$$

10.44 Longest Perpendicular of Jibs, Rated (LP).

LP shall be taken as the greatest of LPG + FSP or J.

10.45 Rated Limits.

For the purpose of calculating the aerodynamic model, the following limits apply.

10.45.1 IM: IM shall not be taken as less than $0.65*(P + BAS)$.

10.45.2 J: J shall not be taken as less than $IM/4$.

10.45.3 LP: LP shall not be taken as less than J.

10.45.4 SMW: SMW shall not be taken as less than the greater of $1.5*J$, or $SMW + .5*(1.5*SPL - SMW)$.

10.45.5 AMG: AMG shall not be taken as less than the greater of $1.5*J$, or $AMG + .5*(1.5*SPL - AMG)$. (SPL is replaced with TPS in this formula for boats rated as centerline asymmetric.)

10.45.6 SF: SF shall not be taken as less than the greater of $1.5*J$, or $SF + .5*(1.5*SPL - SF)$.

10.45.7 ASF: ASF shall not be taken as less than the greater of $1.5*J$, or $ASF + .5*(1.5*SPL - ASF)$. (SPL is replaced with TPS in this formula for boats rated as centerline asymmetric.)

10.45.8 SL & ASL: SL & ASL shall not be taken as less than the spinnaker Luff Limit (LL).

$$LL = 0.95*(ISP^2 + J^2)^{0.5}$$

10.46 Aerodynamic Drag of Masts.

The aerodynamic drag of the masts shall be taken into account by the Velocity Prediction Program and will be determined from the Effective Height of Mainmast (EHM), the Effective Diameter of Mainmast (EDM), the Effective Height of Mizzenmast (EHMY) and the Effective Diameter of Mizzenmast (EDMY).

10.47 Aerodynamic Drag of Rigging and Spreaders.

The aerodynamic drag of the rigging is calculated by deriving an effective diameter from the rigging default weight (see 725.6), divided by the specific gravity of steel and four times IM. This value is then multiplied by IM to obtain an effective rigging windage area which is corrected to take into account the effect of spreaders. Where the mast does not have bona fide spreaders, the drag for spreaders is omitted and that for rigging reduced.

10.48 Effective Height of Mainmast (EHM).

EHM is the greater of $P + BAS$ or IM

10.49 Effective Diameter of Mainmast (EDM).

$$EDM = (0.5*(EHM-TL)*(MDT1+MDL1)+0.25*TL*(MDT1+MDL1+MDT2+MDL2))/EHM$$

For the purpose of calculating EDM, the following limits apply:

MDL1 shall not be taken as greater than MDL1max.

MDL1max shall equal the lesser of $0.036*(RM25*IG)^{0.25}$ or $2*MDT1$.

MDT1 shall not be taken as greater than $(0.036*(RM25*IG)^{0.25})*(MDT1/MDL1)$.

MDL2 shall not be taken as greater than $2*MDT2$.

Where the measured value of MDL1 exceeds MDL1max, the value of any excess shall be added to the mainsail girths MGL, MGM, MGU and MGT for the purpose of calculating mainsail area (see 10.42.4).

Where, in the taper of any mast presented for measurement and built after 1/1/97, a hollow is found in the fore and aft profile (see **TH** on the Certificate), EDM shall be calculated as follows:

$$EDM = (0.5*(EHM-TL)*(MDT1+MDL1)+0.25*TL*(MDT1+MDT2+2.2*MDL2))/EHM.$$

10.50 Effective Height of Mizzenmast (EHMY).

$$EHMY = PY + BASY$$

10.51 Effective Diameter of Mizzenmast (EDMY).

$$EDMY = (0.5*(EHMY-TLY)*(MDT1Y+MDL1Y) + 0.25*TLY*(MDT1Y+MDL1Y+MDT2Y+MDL2Y))/EHMY$$

For the purpose of calculating EDMY, MDL1Y and MDL2Y shall not be taken as greater than 2 times MDT1Y and MDTY2 respectively.

INDEX

AA	Age Allowance	Appendix 6
AMG	Asymmetric Spinnaker Mid Girth	10.23
ASF	Asymmetric Spinnaker Foot	10.22
ASL	Asymmetric Spinnaker Luff (see also SLU & SLE)	10.21
BAL	Boom After Sheeting Limit	9.10.2
BALY	Boom After Sheeting Limit, Mizzen	9.19.2
BAS	Main Boom Above Sheerline	9.09
BASY	Mizzen Boom Above Sheerline	9.18
BCW	Base Crew Weight	8.11
BD	Boom Diameter, Main	9.11
BDY	Boom Diameter, Mizzen	9.20
BLRI	Ballast-Leeward Recovery Index	2.02.2
CANT	Cant Angle -- Canting Keel	Appendix 7, 2.d
CPW	Chainplate Width	9.13
CW	Crew Weight	9.11
DA	Dynamic Allowance	Appendix 6
DCW	Declared Crew Weight	8.12
DHK	Maximum Draft Including Keel	6.13
DHKA	Draft of Keel and Hull Adjusted	6.14
DSPM	Displacement in Measurement Trim	6.11
DSPS	Displacement in Sailing Trim	6.11
E	Foot of Mainsail	9.10.1
EB	Distance Between Masts	9.21
EDM	Effective Diameter Main Mast	10.49
EDMY	Effective Diameter Mizzen Mast	10.51
EHM	Effective Height of Main Mast	10.48
EHMY	Effective Height Mizzen Mast	10.5
EY	Foot of Mizzen	9.19.1
FSP	Forestay Perpendicular	10.14
GO	Forestay Outtrigger	9.06.3
GPH	General Purpose Handicap	Appendix 4, 4.a
GSA	Gauge Surface Area, Inclining Manometer	8.02
HB	Headboard of Mainsail	10.3
HBS	Spinnaker Headboard	10.19

HBY	Headboard of Mizzen	10.35
HMI	Hull Measurement Instrument	1.04
IG	Height of Genoa Hoist	9.06.1
IM	Foretriangle Height	10.43
ISP	Height of Spinnaker Halyard	9.06.2
IY	Height of Mizzen Mast	9.15
J	Base of Foretriangle	9.04
JL	Longest Luff of Jibs	10.15
JR	Jib Roach	10.13.5
L	Sailing Length	6.10
LIST	List Angle -- Moveable Ballast Yachts	Appendix 7, 1.e
LL	Luff Limit of Spinnaker	10.45.8
LOA	Length Overall	6.04
LP	Longest Perpendicular of Jibs, Rated	10.44
LPG	Longest Perpendicular of jibs	10.12
LPS	Limit of Positive Stability	2.02.1
MB	Maximum Beam (nominal)	6.05
MCG	Mast Vertical Center of Gravity	8.14.1
MDL1	Maximum Longitudinal Dimension of Main Mast	9.06.6
MDL1Y	Maximum Longitudinal Dimension of Mizzen Mast	9.16
MDL2	Longitudinal Dimension of Main Mast at Head	9.06.9
MDL2Y	Longitudinal Dimension of Mizzen Mast at Head	9.16
MDT1	Maximum Transverse Dimension of Main Mast	9.06.5
MDT1Y	Maximum Transverse Dimension of Mizzen Mast	9.16
MDT2	Transverse Dimension of Main Mast at Head	9.06.8
MDT2Y	Transverse Dimension of Mizzen Mast at Head	9.16
MGL	Mainsail Girth, Lower	10.32.1
MGLY	Mizzen Girth, Lower	10.37
MGM	Mainsail Girth, Mid	10.32.1
MGMY	Mizzen Girth, Mid	10.37
MGT	Mainsail Girth, Top	10.32.1
MGTY	Mizzen Girth, Top	10.37
MGU	Mainsail Girth, Upper	10.32.1
MGUY	Mizzen Girth, Upper	10.37
MSW	Mainsail Weight	10.33

MW	Mast Width	9.06.4
MWT	Mast Weight	8.14.1
P	Mainsail Hoist	9.07
PIPA	Propeller Installation Projected Area	2.04
PL	Pendulum Length, Inclining Manometer	8.02
PLM	Pendulum Length, Measured, Inclining Manometer	8.02
PY	Mizzen Hoist	9.17
RM	Righting Moment	8.07
RMC	Righting Moment Corrected	8.08
RM2	Righting Moment per Degree in Sailing Trim at 2 degrees heel	8.09
RM20	Ditto 20 Degrees Heel	8.10
RM40	Ditto 40 Degrees Heel	8.10
RM60	Ditto 60 Degrees Heel	8.10
RM90	Ditto 90 Degrees Heel	8.10
RSA	Reservoir Surface Area, Inclining Manometer	8.02
SF	Symmetric Spinnaker Foot Length	10.22
SFJ	Stem to forward end of J	9.04.1
SG	Specific Gravity, Flotation Measurement	5.02.1
--	Sheer Point	5.01.4, Appendix 3
--	Sheer Line	5.01.5
SL	Symmetric Spinnaker Luff/Leech Length	10.21
SLE	Asymmetric Spinnaker Leech	10.21.2(b)
SLU	Asymmetric Spinnaker Luff	10.21.2(a)
SMW	Symmetric Spinnaker Maximum Width	10.20
SPL	Spinnaker Pole Length	9.05.2
--	Stability Index	2.02.1
TH	Taper Hollow	10.49
TL	Tapered Length of Main Mast	9.06.7
TLY	Tapered Length of Mizzen Mast	9.16
TPS	Tack Point, Spinnaker	9.05.3
VPP	Velocity Prediction Program	1.02

WB	Weight of Boom	9.14.4
WBV	Water Ballast Volume	Appendix 7
WD	Weight Distance, Inclining Weights	8.03
WSS	Wetted Surface, Upright Sailing Trim	6.12
YSD	Mizzen Staysail Depth	10.40
YSF	Mizzen Staysail Foot	10.39
YSMG	Mizzen Staysail Mid Girth	10.4

APPENDIX 1 -- ORR RATING CERTIFICATE

SAMPLE CERTIFICATE WILL BE AVAILABLE WITH NEXT UPDATE

APPENDIX 2 -- MEASUREMENT CONDITION CHECK LIST & INVENTORY

This check list is intended to help the owner prepare the yacht for measurement. Each item checked will be initialed by the owner and Measurer. The completed document will be returned to the Rating Office for retention. The yacht shall be completed and equipped for sailing. There shall be no sails aboard at the time of the check below deck.

		Initials	
		Owner	Measurer
1.	All sails removed from the yacht.
2.	Ballast sealed to hull structure and anchors, chain and batteries fixed in clearly marked stowage.
3.	Heads, bowls, sinks, etc. are dry.
4.	Bilges and other possible areas where water may collect are dry.
5.	Tankage and voids condition checked.
6.	Navigational and cooking equipment stowed as specified.
7.	No clothing, bedding, food or stores on board.
8.	Mattresses, cushions and pillows stowed in normal position (dry)
9.	No portable equipment in front of the mast.
10.	Safety gear stowed in normal position, but not forward of the mast.
11.	All stowages opened and checked.
12.	No liferaft or dinghy on board.
13.	Centerboards raised unless to be locked down while racing.
14.	Sheets, guys, etc. on cabin sole abaft the mast according to 502.2.a.2.
15.	Measurement bands PAINTED on spars.
16.	All standing rigging tight.
17.	Running rigging tight. Halyards led to the foot of the mast and tails to their normal operating position.
18.	Running backstays aft and tight, running forestays to the mast.
19.	Masts raked aft to the limit of adjustment, not forward of vertical.
20.	Boom at low point, horizontal, centered and secured against movement.
21.	No spinnaker pole(s) aboard while measuring freeboards.

Signed(Owner)(Measurer)

Dated:

APPENDIX 3 -- Various Sheer Points

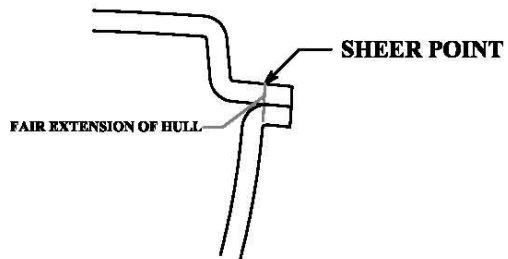
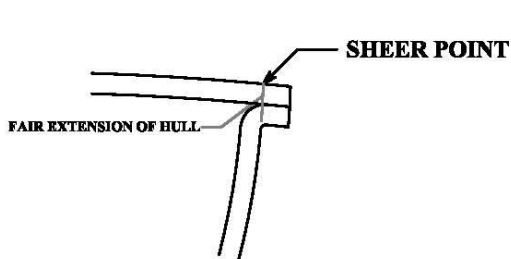
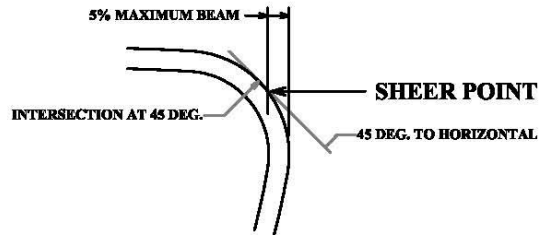
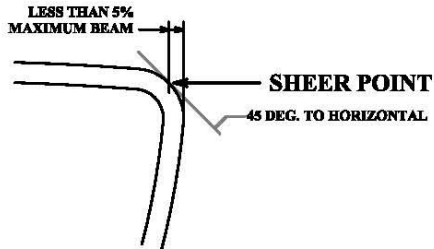
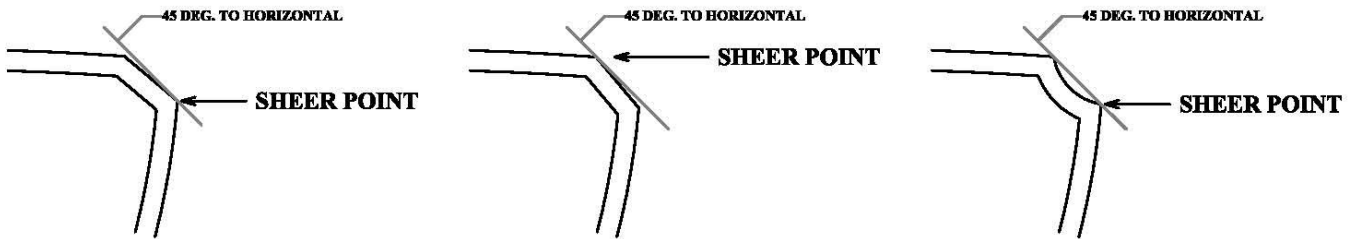
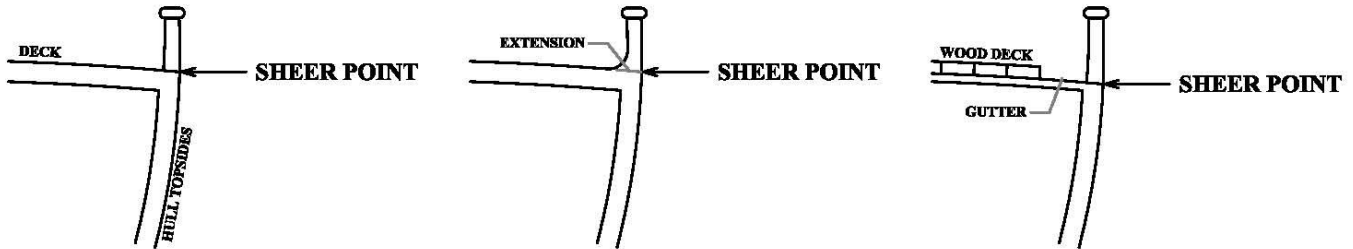

APPENDIX 4 -- RULES AND PROCEDURES FOR RACE ADMINISTRATION

Unless otherwise prescribed by the Sailing Instructions, the following shall apply to races conducted under the ORR.

1. Pre-race Inspection or Measurement.

When, as a result of any pre-race inspection or measurement, it is determined that a yacht does not conform to its ORR certificate:

- a) When the nonconformance is considered to be minor and can be easily corrected, the yacht may be brought into conformance with her certificate, or, when necessary, a new certificate may be issued.

The measurer appointed for the series shall report all such corrections to the protest committee.

- b) When the protest committee considers that the nonconformance is major (even if it can be corrected) or that it cannot be corrected without requiring significant remeasurement, they shall act in accordance with RRS.

2. During a Race or Series.

When, as a result of an inspection, measurement, or protest during a race or series, it is determined that a yacht does not conform to its certificate, the facts shall be referred to the protest committee which shall act in accordance with the RRS.

- a) When the nonconformance is considered to be minor (whether or not the yacht is issued with a new certificate), the original certificate shall be considered valid throughout the race or series.
- b) When the nonconformance is not considered to be minor the yacht shall receive a 50% place penalty in any race in which her rating was incorrect.
- c) When a yacht's Certificate is withdrawn by a Rating Authority the matter shall be referred to the protest committee which shall act in accordance with the RRS and may disqualify the yacht from all races in the series or take such other action as it deems proper.
- d) The results of a race or series shall not be affected by measurement protests lodged after the prize-giving or such other time as the Sailing Instructions shall prescribe. Nothing in this paragraph shall bar action under the RRS concerning a yacht deliberately altered.

3. General.

- a) When a yacht is checked at an event or as a result of a protest, the measurement shall be checked using the rule as it was in effect at the time of measurement upon which the certificate is based (see 6.03 for hull re-measurement).
- b) The Rating Authority in whose waters the yacht is racing would normally be the "authority qualified" referred to in the RRS to resolve questions involving ORR certificates. A protest committee considering a protest involving an ORR certificate may submit questions to the Rating Authority which shall provide all reasonable advice and assistance to resolve the protest. The measurements resulting from a protest re-measurement shall be used to issue any new Certificate.

4. Investigation and Reporting of Rating Irregularities.

- a) When, as a result of an action in a race or series or the withdrawal of a certificate by a Rating Authority, a yacht is remeasured and her resulting General Purpose Handicap (GPH) is faster by 0.75% or more, the yacht's National Authority shall investigate the circumstances and report its findings to the ORA which may take such further action as it deems proper.
- b) Race and protest committees are asked to report all actions arising under 1(b), 2(b) and 2(c) above to the ORC Chief Measurer. Such reports may be made through the National Authority of the organizing authority.

5. Other Actions.

This Appendix only concerns actions with respect to yachts. It does not limit in any way the rights and responsibilities of race and protest committees and of National Authorities to investigate or act with respect to individuals.

APPENDIX 5 -- ADMINISTRATIVE RATING PROTESTS

1. The Offshore Racing Association shall be the Rating Authority referred to in the ISAF Rules to resolve questions involving ORR Certificates. A protest committee considering a protest involving an ORR certificate may submit questions to that Rating Authority which shall provide all reasonable advice and assistance to resolve the protest.
2. Administrative Protests.
 - a) The administrative protest procedure permits protests involving a yacht's certificate without regard to whether the yacht was racing. An administrative protest shall be lodged with the Rating Authority in whose water the yacht is lying.
 - b) Any person or organization which has a valid interest in a yacht's certificate may lodge an administrative protest, provided that:
 - The protest is in writing and is signed and dated by the protestor;
 - The protest includes a detailed description of the alleged defects and a full statement identifying the protestor as having a valid interest;
 - The protest is accompanied by a copy of the certificate of the yacht being protested and the address and telephone number of the protested yacht's owner;
 - The protest includes a statement of the issues the protestor wishes to have resolved, identification of the applicable rules and any relevant evidence.
 - c) The owner of the protested yacht shall file a reply with the Rating Authority as soon as possible. If he elects to concede the protest or refuses to cooperate in providing for re-measurement when required, the Rating Authority shall invalidate the yacht's certificate and so advise all concerned, including the local organization within whose jurisdiction the yacht normally races.
 - d) The Rating Authority may consult or refer the matter to the ORR Chief Measurer for advice and assistance. It shall make its decision based on the available evidence and may order re-measurement of the yacht in whole or in part (see 6.03 for hull re-measurement).
 - e) The decision of the Rating Authority shall determine any measurement and processing costs of deciding the protest and determine which party will pay, as follows:
 - When the correct General Purpose Handicap (GPH) of the protested yacht is faster than the protested GPH by not more than 0.25%, the protestor will be responsible for the measurement and processing costs. The filing fee will not be counted toward payment of costs.
 - When the correct GPH is faster than the protested GPH by more than 0.25%, the measurement and processing costs will be borne (or shared) by the owner or the yacht's Revalidating Authority depending upon the determination of responsibility for the defect. The filing fee will be returned to the protestor.

3. Redress from Actions of the Rating Authority.
 - a) When an owner believes that his yacht's certificate is being withheld unreasonably or that any related actions of the Rating Authority are unreasonable, he may seek redress by following the applicable procedures set out in 2. Administrative Protests above, stating the relevant facts and the relief or redress requested.
 - b) The Rating Authority concerned shall appoint a committee to investigate, hear, and decide on the request following the procedures of the ISAF Racing Rules. In the event that there is reasonable doubt as to the interpretation or application of the ORR, the ORA Chief Measurer shall be the "authority qualified" to resolve such questions.

APPENDIX 6 -- DYNAMIC & AGE ALLOWANCES

1. Dynamic Allowance (DA)

Dynamic Allowance is an adjustment which may be applied to velocity predictions (i.e., time allowances) to account for relative performance degradation in unsteady states (e.g., while tacking) not otherwise accounted for in the VPP performance prediction model. DA is a percentage credit calculated on the basis of design variables deemed to be relevant in assessing the performance degradation and is applied (or not applied) as explained below. Even where applied, the result of the calculated credit may be zero. Examples of design variables considered appear below.

Where applied, the calculated amount of credit will vary with point of sail and wind velocity and course type. These credits are therefore applied individually to the various time allowances available within the ORR. The single value for DA which is actually displayed on the certificate is that which was applied to GPH and is shown only to give a comparative reference to the average DA applied for the yacht.

DA percentage credits are always fully applied to the time allowances. For other yachts, no DA is applied for the first three years of age (as defined in 2 below). Thereafter, DA is applied incrementally with only 20% of the full calculated DA being applied in the fourth year and a further 20% in each of the following years until full DA is applied in the eighth year.

Typical design parameters for ORR Dynamic Allowance:

- Length: Effective sailing length
- Draft: Effective keel draft
- SAup: Upwind sail area
- SAdn: Downwind sail area
- VOL: Volume of displacement (weight of boat divided by density of water)
- WA: Wetted area of hull (including appendages)
- Draft: Effective keel draft

Typical non-dimensional design factors for ORR Dynamic Allowance:

- SAup / (VOL)^{2/3}
- SAup / WA
- SAdn / (VOL)^{2/3}
- SAdn / WA
- Length / (VOL)^{1/3}
- Draft / Length

2. Age Allowance (AA)

Independent of DA, an Age Allowance of 0.05% increase in time allowance is applied for a one-year old yacht. From the second year to a maximum of 20 years, the Age Allowance is calculated as:

$$AA = 0.00017 * \text{Age}^3 - 0.011 * \text{Age}^2 + 0.25 * \text{Age} - 0.35$$

The age used for Age Allowance is the earlier of Age Date or Series Date (see 1.05.1 & 1.05.2). The reference year is the current rule year. This allowance is applied to all yachts.

APPENDIX 7 -- WATER BALLAST & SPECIAL APPENDAGES

A yacht holding a valid certificate under this Appendix shall be deemed not to contravene ORR 4.04, Shifting of Ballast (nor RRS 51) with regard to the features rated hereunder.

Stability:

Rating Certificates for canting keel and water-ballasted yachts display both the Stability Index and also a Ballast-Leeward Recovery Index (BLR Index). The BLR Index is related to a yacht's estimated ability to recover from a knockdown to windward where the moveable ballast is on the leeward side. Recommended BLR Index minimum limits and the formula for calculation of the BLR Index is given in ORR 2.02.2, General Limits and Exclusions, Stability.

The stability criteria for moveable ballast yachts (water ballast or canting keel) have been set to achieve similar levels of capsize resistance and recovery as conventional yachts. However the defining feature of moveable ballast yachts is that, with the ballast deployed, they have an angle of list, i.e. a static heel angle that is not upright. Consequently the energy required to heel the yacht to 90 degrees (i.e., spreaders in the water) is greater when heeling with the ballast to windward (normal sailing) than it is with the ballast to leeward (caught aback). When available, it is planned to display on the certificate of each moveable ballast yacht three values that define this situation for that specific yacht and provide a means of comparison with conventionally ballasted yachts of similar size.

- 1) the area under the righting moment curve to 90 degrees of heel with ballast to windward.
- 2) the area under the righting moment curve to 90 degrees of heel with ballast to leeward.
- 3) an average area under the righting moment curve of a selection of conventionally ballasted ORR yachts of a similar sailing length.

These values are not directly entered into the Stability Index or BLRI Index, but do offer an indication of the relative ease with which the vessel may be heeled to 90 degrees, both under normal sailing conditions and when "caught aback". Owners and crew should be aware of the different characteristics of moveable ballast yachts when the ballast is to windward as well as to leeward.

Measurement:

Where the following provisions for water-ballasted yachts and special appendages are in conflict with ORR Part 2, General Limits and Exclusions, the provisions below shall take precedence. There is currently no provision for rating a yacht with both water ballast and a canting keel.

1. Water Ballasted Yachts

- a) Water ballast tanks shall be symmetrical about the yacht's centerline and no provision for trimming the yacht fore and aft is permitted.
- b) For measurement afloat (see 5.02), the yacht shall first be measured with ballast tanks empty and the full set of flotation and inclining measurements recorded as for conventional yachts.
- c) The ballast tank(s) on the starboard side of the yacht shall then be filled, pressed up and the resulting angle of list recorded.

- d) The port ballast tank(s) shall then also be filled, pressed up and a full in-water measurement performed as in 1(b) above, except with all ballast tanks full. The full set of in-water measurements shall be recorded as was done for the tanks-empty measurement, except that the corresponding datafield names include the suffix "W".
- e) The starboard ballast tank(s) shall then be emptied and the resulting list angle recorded. The port and starboard list angles shall be reported to the Rating Office and where these are not approximately equal, the yacht may be deemed not to comply with the provision above for symmetric ballast tankage. The average of the port and starboard list angles shall be recorded as **LIST** to the nearest tenth of a degree.
- f) The ORR time allowance for each true wind angle and true wind velocity will be given as the faster of a comparison between calculated performance with ballast tankage on only the windward side of the yacht full and that with both tanks empty in the respective sailing condition.

2. Canting Keel Yachts

- a) A canting keel may pivot laterally only about a longitudinal axis aligned with the centerline of the yacht and no other movement is permitted. The maximum cant angles, port and starboard respectively, shall be symmetric.
- b) For measurement afloat (see 5.02), the yacht shall first be measured with the keel on centerline and the full set of flotation and inclining measurements recorded as for conventional yachts.
- c) The keel shall then be canted fully to starboard. The resulting list angle shall be recorded and the angle of the keel relative to the yacht's centerplane also recorded. These measurements shall be repeated and recorded with the keel canted fully to port.
- d) The port and starboard list angles shall be reported to the Rating Office and where these are not approximately equal, the yacht may be deemed not to comply with the provision above for symmetric cant angles. The average of the port and starboard list angles shall be recorded as LIST to the nearest tenth of a degree. The average of the port and starboard cant angles shall be recorded as CANT to the nearest tenth of a degree.
- e) The ORR time allowance for each true wind angle and true wind velocity will be given as the faster of a comparison between calculated performance with the keel fully canted to the windward side of the yacht and that with the keel centered in the respective sailing condition.

3. Bilge Boards

Bilge boards with motion only up and down in a straight line are permitted, subject to the restriction of angular motion as provided also for centerboards under 2.03.7.2. The location and vertical extension of bilge boards shall be taken as part of the machine hull measurement procedure (see Part VI) and their draft determined from the Hull Offset File (see 6.02) at various angles of heel.

4. Trim Tabs

A movable trim tab is permitted. The fitting of such a trim tab shall be recorded. The effect on performance of a moveable trim tab will be calculated to reflect a reduction in leeway angle.